

USER'S  
MANUAL

---

# LINEUP™ SERIES

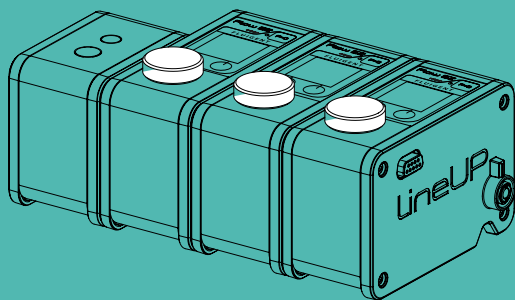

 FLUIGENT

# QUICK START GUIDE

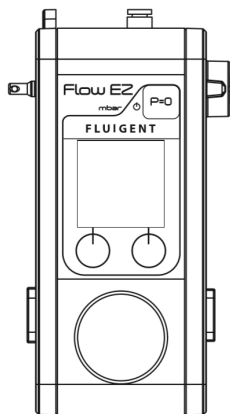

## LineUp Flow EZ™

Pressure controller

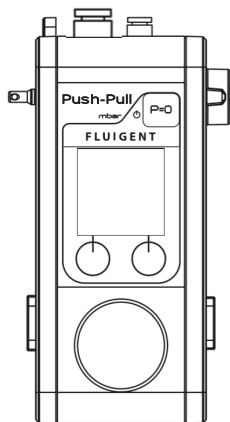

## LineUp™ Push-Pull

Pressure controller

The **quick start guide** is a forward to the LineUp™ Series user's manual

### AN OVERVIEW OF PRESSURE-BASED MICROFLUIDIC CONTROL

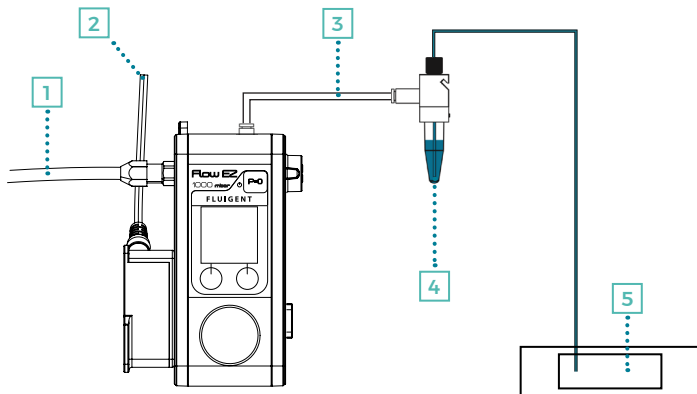

- 1 Supplied (inlet) pressure from pump or compressed air supply
- 2 Power supply to the Flow EZ™ / Push-Pull pressure controller
- 3 Regulated (outlet) pressure from pressure controller to reservoir
- 4 Pressurized reservoir P-CAP
- 5 Microfluidic set-up in example a microfluidic chip

1. The **Flow EZ™ / Push-Pull** regulates the externally supplied (inlet) pressure to a user-defined pressure with **high precision**.
2. This regulated (outlet) pressure **pressurizes the reservoir**, driving the liquid up through the tubing and into the **microfluidic setup**.
3. Controlling the outlet pressure allows one to **control the rate** at which fluid is injected into the microfluidic setup.

## WHAT IS NEEDED

### Contained in the package

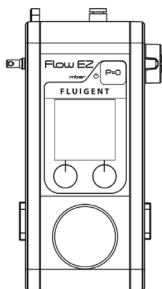

Flow EZ™ or Push-Pull

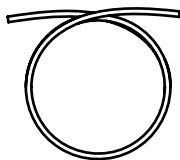

Outlet tubing (OD 4mm)

\*OD: Outer diameter

### P-CAP Kit or Fluiwell Kit (sold separately)

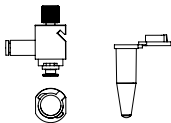

P-CAP (or Fluiwell) reservoir

Fluiwell: for 15mL or 50mL reservoirs  
P-CAP for 2mL, 15mL or 50mL reservoirs

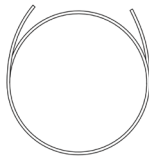

Fluidic tubing

Outer diameter and inner diameter  
depending on the Kit

**LineUp™ supply Kit (sold separately)**

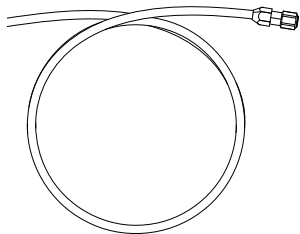

Inlet tubing (OD: 6mm)

\*OD: Outer diameter

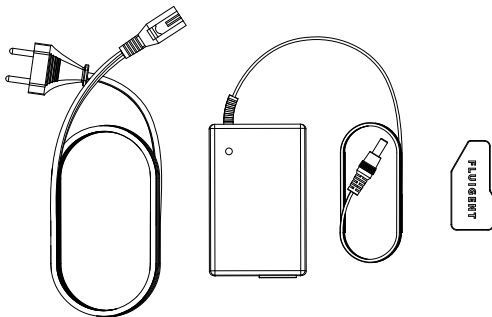

Power supply (24VDC)

Power supply to Sub-D adaptor

## POWER ON

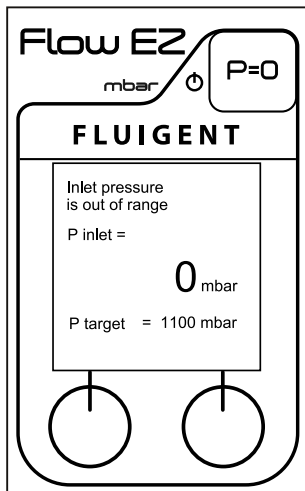
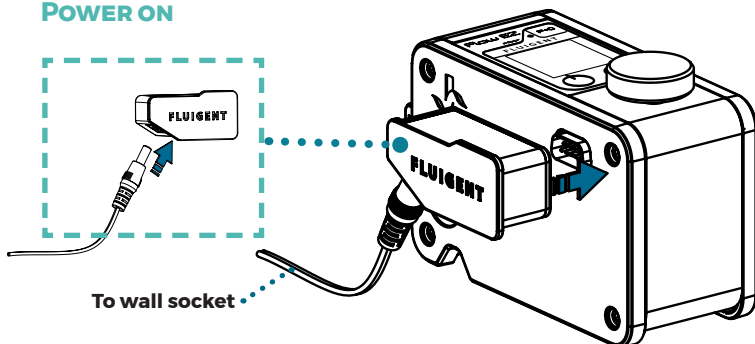

Once powered on, the **Flow EZ™** or **Push-Pull** will display the "Inlet pressure check window", giving the **measured pressure** at the inlet (P inlet) and the **supply pressure required** to operate the pressure controller (P target).

For example, left shows a 1000 mbar range **Flow EZ™**

P target : 1100 mbar  
P inlet : 0 mbar

**Note** : For the 7000 mbar range as well as negative pressure ranges **Flow EZ™**, this window will not appear.

## QUICK START GUIDE



Always wear safety protection when manipulating pressure.

## PRESSURE ON

- For positive range, **never exceed** 8 bar (120 psi)
- For negative range, **never connect** any positive pressure

Pressure supply

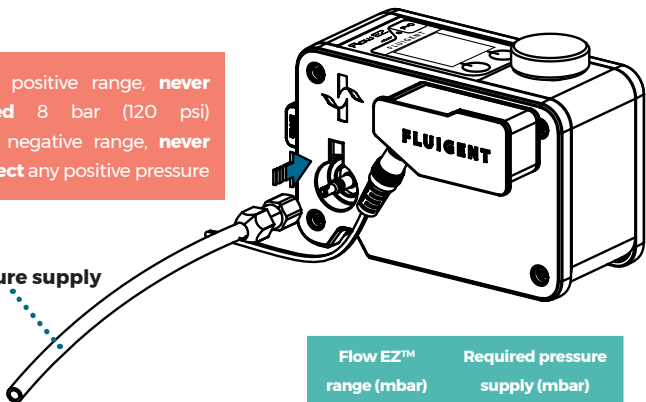

The **Flow EZ™** or **Push-Pull** needs an **external pressure supply** to operate. This can be a lab's compressed air supply, an air compressor, or any clean (filtered < 10 µm) and dry compressed air supply.

Different **Flow EZ™ ranges** require different supply pressures (shown to the right).

Flow EZ™ range (mbar)	Required pressure supply (mbar)
7000	7100
2000	2100
1000	1100
345	
69	150
25	
-25	
-69	
-345	-800
-800	

**Note:** If one intends to use compressed gas other than air, or if the pressure supply is out of the pressure range requirements, please contact Fluigent.

## PUSH-PULL SPECIFICITIES

The **Push-Pull** module works the same way as other **Flow EZ™** modules, except that it can output **pressure** (above atmospheric pressure) and **vacuum** (below atmospheric pressure) **through the same port**.

Push-Pull output (mbar)	Required pressure supply (mbar)
1000	1100
-800	-800

To do so, it needs **two inlets**: the positive one, uses the **standard pressure supply** of the **Flow EZ™**, and the negative one, utilizes an **additional connector located** at the front between the **FLOW UNIT** port and the "unlock" handle.

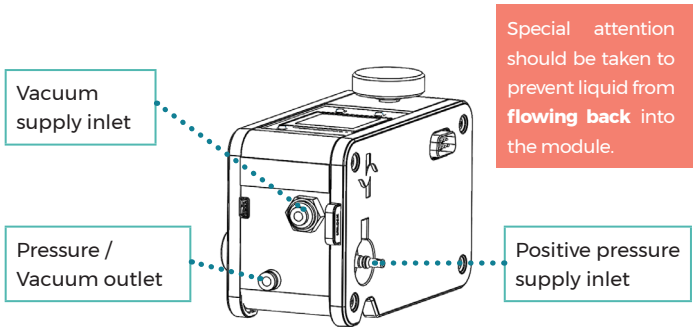

**Note** : Depending on the supply pressures, the performance of the module can vary, especially for the vacuum pressure supply. When connecting the two supplies, only the positive pressure supply will be checked on the "Inlet pressure check window". (see page 10)



## QUICK START GUIDE

A **Push-Pull** module can be combined with other **positive pressure LineUP™** modules the same way as a **Flow EZ™** 1 bar. If connecting to **higher pressure modules**, please consider adding an **Adapt** module to reduce the positive pressure supply. (See page 29 for more details)

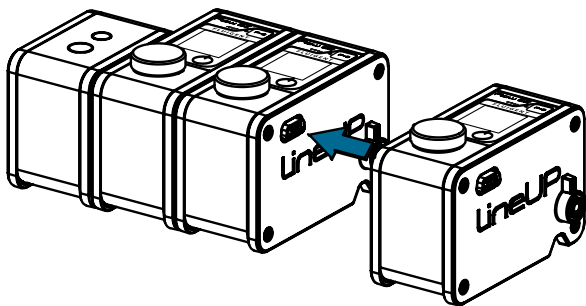

When using a **Push Pull** module, **care** should be taken to avoid drawing liquid into the system. This can seriously damage the module. It is advised to use a **liquid filter** between the outlet and the reservoir as it reduces the risks.

**Note** : The **Push-Pull** can be used as a regular **Flow EZ™** with no vacuum supply connected.

Please, **never stack** a **Push-Pull** module with a **negative Flow EZ™** as it would not work.

## ADJUST THE SUPPLIED PRESSURE

(A 1000 mbar range Flow EZ™ is shown as an example)

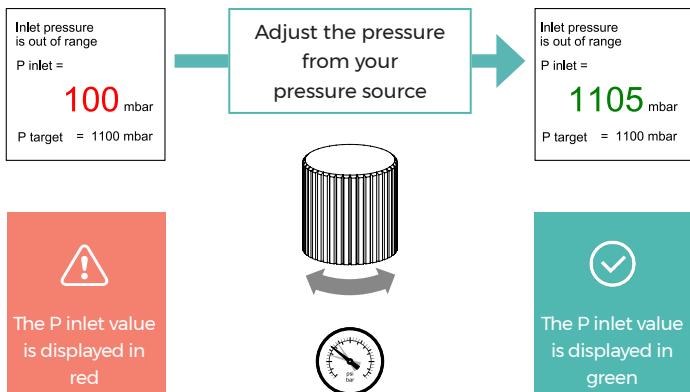

When connecting the pressure supply, if its value (P inlet) is **not set** at the **required value** (P target), the **Flow EZ™** or **Push-Pull** will continue to display the "Inlet pressure check window" (with the exception of the 7000 mbar range and the negative ranges which don't have this window)

If the value is **displayed in red**, please **adjust the pressure supply**.

When the two values are close enough, the **P inlet value** will **turn green** and the display on the **Flow EZ™** or **Push-Pull** will transition to "Operation window"

## OPERATION WINDOW

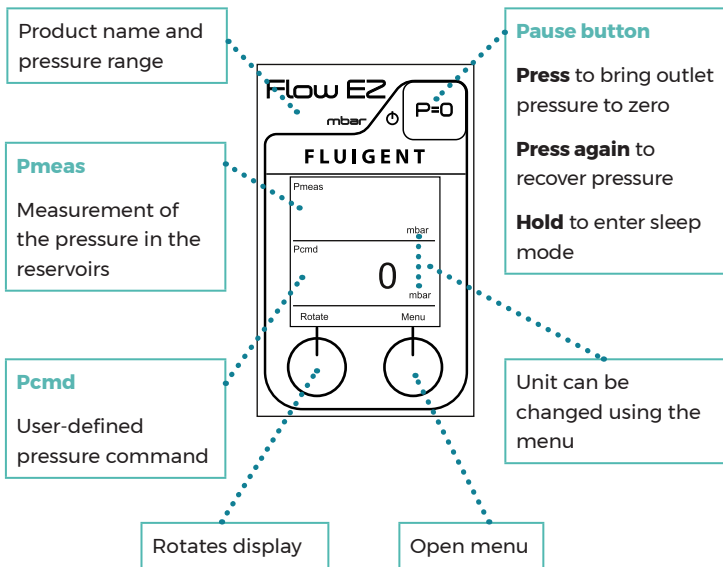

The pressure sensor inside the **Flow EZ™** or **Push-Pull** device needs to be **calibrated before the first use** (see next page).

If the system isn't calibrated, the outlet measured pressure (Pmeas) may be incorrect.

## PRESSURE SENSOR CALIBRATION

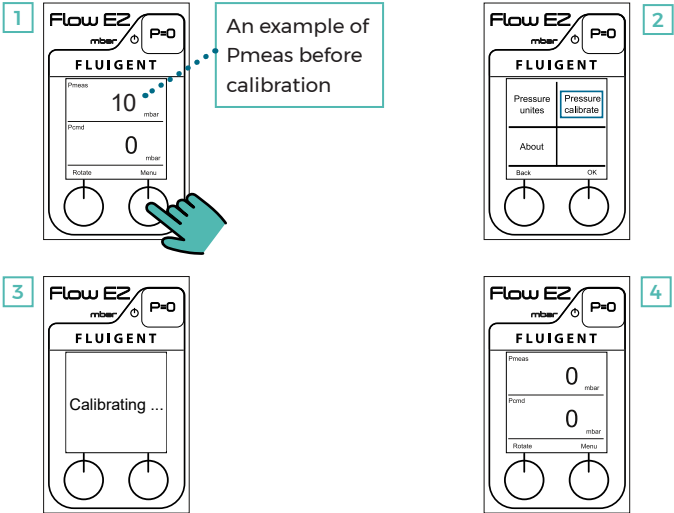

1. Press "Menu"
2. Use the dial (turn and press) to select "*Pressure calibrate*"
3. Wait a few seconds
4. The calibration is done

**Note:** Due to the high sensitivity of the internal pressure sensor, one may observe some small fluctuations of the measured pressure ( $P_{meas}$ ), even after the calibration is complete.

## CONNECTION TO THE FLUIDIC SETUP

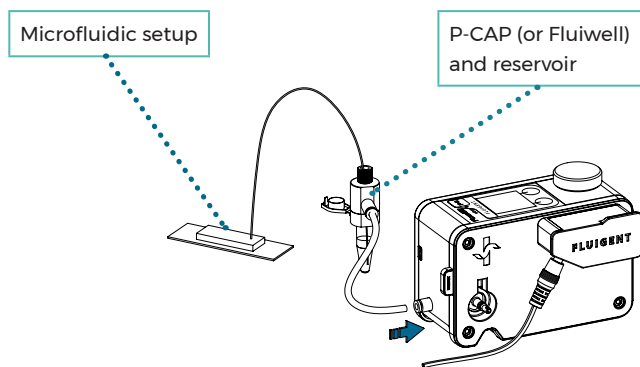

One can connect a **FLOW UNIT** (Fluigent flow sensor) between the reservoir and the microfluidic setup. (See page 22 for more details)

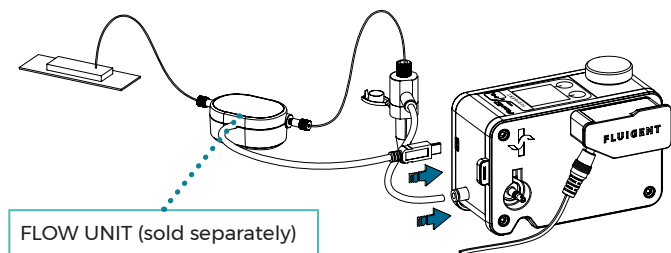

## WHEN DONE WITH THE FLOW EZ™ / PUSH-PULL

When one has finished using the **Flow EZ™** or **Push-Pull**, hold the "P=0" button in order to put the device into **sleep mode**.

If one needs to **disconnect the power supply** (e.g. to move or store the unit), please make sure the **Flow EZ™** or **Push-Pull** is already in **sleep mode before disconnecting the power**.

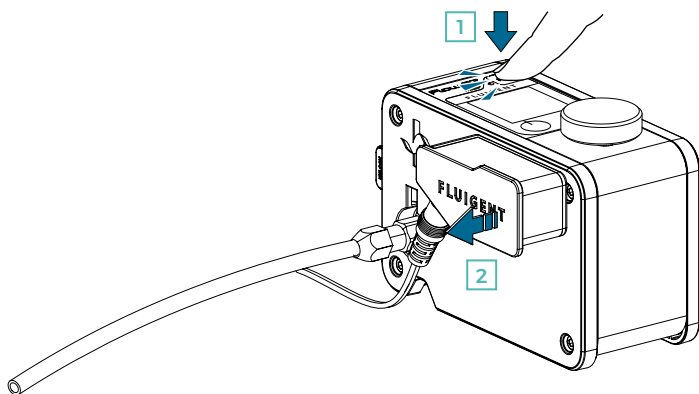

This procedure will **release all residual pressure** in the system, preventing any further pressure from being applied to your fluidic setup.

For a fully detailed **shutdown procedure**, please see page 32.



The **Flow EZ™** or **Push-Pull** is ready to be used,  
Simply turn the dial to start.

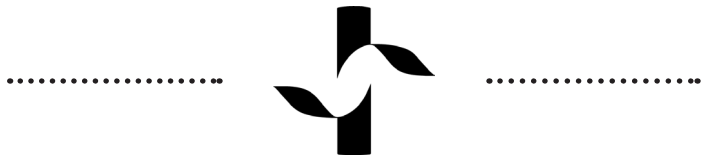
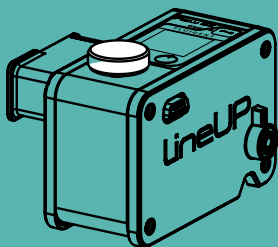

The **user's manual** is on the next page:

Allowing one to get the most out of the **LineUp™ series** devices.







# LINEUP™ SERIES USER'S MANUAL

<b>PRODUCT OVERVIEW</b>	<b>18</b>
<b>SETTING UP</b>	<b>21</b>
A faster way to change the pressure	21
Add a FLOW UNIT	22
Flow rate control	24
Inject a volume	25
Flow-related setting	26
Liquid type	27
<b>SYSTEM EXPANSION</b>	<b>28</b>
Create a multi-channel configuration	28
Mixing different pressure range	29
LineUp™ Adapt	30
<b>COMPUTER CONNECTION</b>	<b>31</b>
LineUp™ Link	31
<b>SHUTDOWN PROCEDURE</b>	<b>32</b>
<b>ADDITIONAL FEATURES</b>	<b>33</b>
<b>FREQUENTLY ASKED QUESTIONS (FAQ)</b>	<b>34</b>
<b>WARRANTY TERMS</b>	<b>36</b>
<b>TECHNICAL SUPPORT</b>	<b>37</b>

# PRODUCT OVERVIEW

LineUp Flow EZ™  
Pressure controller

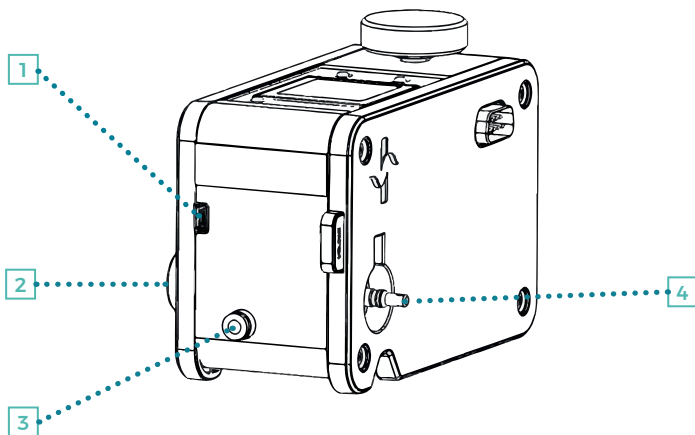

- 
- 1 FLOW UNIT port to the flow sensor
  - 2 Pressure supply transmission used only in multi-channel configuration
  - 3 Pressure outlet to reservoir
  - 4 Pressure inlet from pump or compressed air supply
-

## PRODUCT OVERVIEW

### LineUp Push-Pull Pressure controller

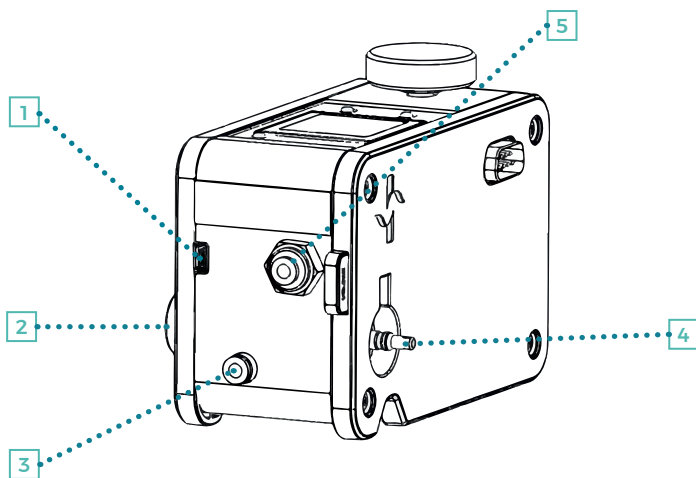

- 
- 1 FLOW UNIT port to the flow sensor
  - 2 Pressure supply transmission used only in multi-channel configuration
  - 3 Pressure outlet to reservoir
  - 4 Positive pressure inlet from pump or compressed air supply
  - 5 Vacuum inlet from vacuum pump
-

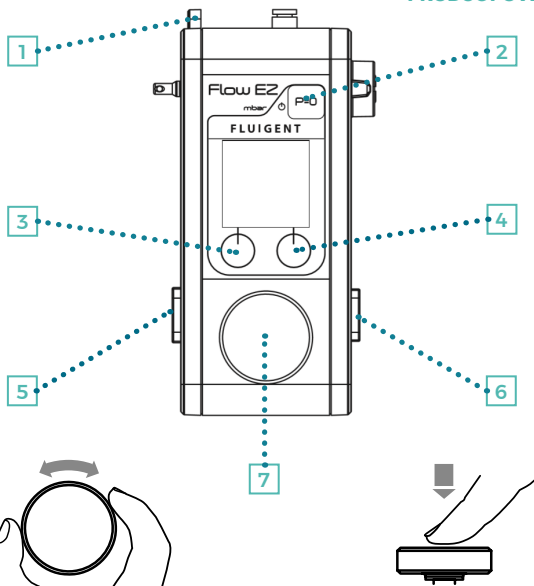

Change pressure command  
Navigate in menu

Set/Apply pressure  
Command set in menu

- 1 Unlock button used only in multi-channel configuration
- 2 P=0 button press once to set pressure to 0, press again to return to original pressure, hold to put into sleep mode
- 3 Left button press to rotate the display/go back
- 4 Right button press to open the menu/enter
- 5 Power / Data connection provide power supply and data connection
- 6 Power / Data transmission used only in multi-channel configuration
- 7 Dial for local control

# SETTING UP

## A FASTER WAY TO CHANGE THE PRESSURE

**Classic way:** Turn the **dial** in the "Operation window" to change the requested pressure, this command is **immediately** and **continuously** applied by the **Flow EZ™** or **Push-Pull**.

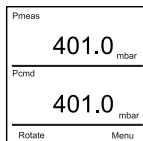
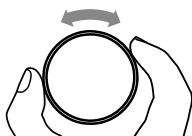
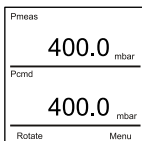

**ON/OFF way:** Click on the **dial**, set the **pressure requested** in advance, and apply it later by **pressing the dial** again. This is a **faster way** to apply a direct pressure command **without overshooting**.

1

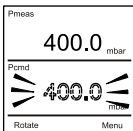
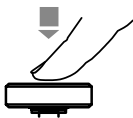

2

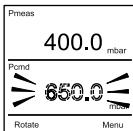
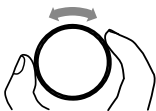

3

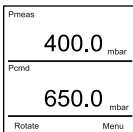
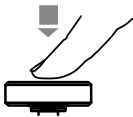

1. Press the dial to enter "command off" mode (the Pcmd value blinks).

2. Set the desired pressure order (Pcmd) by rotating the dial.

3. When one wants to apply the pressure order, press the dial again.

## ADD A FLOW UNIT

The **FLOW UNIT** is Fluigent's **flow rate sensor**. When a **FLOW UNIT** is added, one can use the **Flow EZ™** or **Push-Pull** to:

- **Monitor** the flow rate in the microfluidic set-up
- Directly control the flow rate **locally**
- Perform an **injection**, based on either **volume or time**

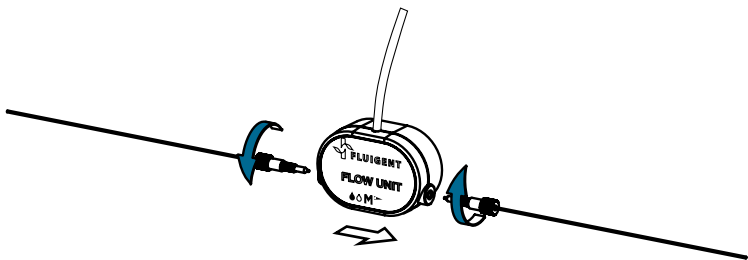

### Insert a FLOW UNIT into the fluidic path

Connect the **FLOW UNIT** inline with **the arrow** indicating the **direction of the flow** to get a **positive value**. This is important for the flow rate control to work properly. Please pay extra attention when using a **Flow EZ™** of **negative range**, or when using a vacuum with a **Push-Pull**, in which case the **values will be negative**.

## SETTING UP

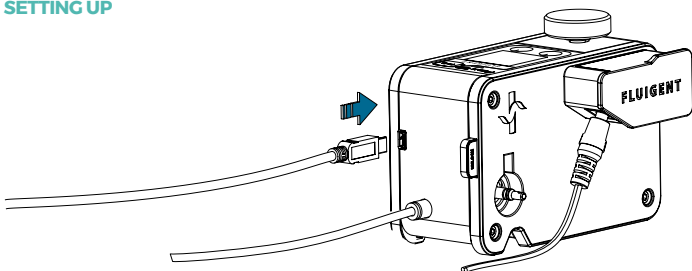

### Connect the FLOW UNIT to the Flow EZ™ or Push-Pull

Use the **dedicated port** on the back of the pressure controller to connect the flow sensor. Once a **FLOW UNIT** is connected, the device **automatically detects** it and the "Operation window" will display an additional zone including the **flow rate measurement**.

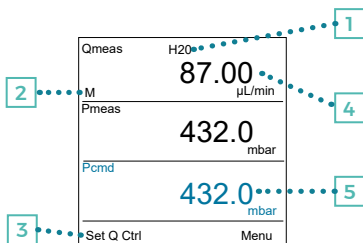

The measured flow rate (Qmeas) is only monitoring purposes. To directly control the flow rate, see next page (Flow rate control)

- 1 Liquid type **H2O** or **Isopropanol**
- 2 Range of the FLOW UNIT depending on the target flow rate (XS, S, M, L, XL)
- 3 Switch to flow rate control mode [see next page](#)
- 4 Measured flow rate **units** can be changed using the menu
- 5 Pressure command **to be set by the user**

## FLOW RATE CONTROL

When a **FLOW UNIT** is connected, press the left button "Set Q Ctrl" to switch to the **flow rate control mode**.

1	Qmeas H20 <b>87.00</b> μL/min	1 Measured flow rate Units displayed can be chosen
	M Pmeas <b>432.0</b> mbar	2 Flow rate command To be set by the user
2	Qcmd <b>87.00</b> μL/min	3 Go back to pressure control mode
3	Set P Ctrl Menu	

The user can directly **control the flow rate**, by setting the flow rate command (Qcmd)

Although the **control mode** is in flow rate, the **live pressure** section value in the reservoir (Pmeas) is **still displayed** in the middle, giving information on the fluidic set-up. Abnormal flow rates may reflect problems in the microfluidic set-up (leakage, clogging, etc.)

See Fluigent FAQs on [www.fluigent.com](http://www.fluigent.com) for more information.

**Direct flow rate control** works only when the value of **measured flow rate** (Qmeas) is **positive**. If it is not the case, please verify that the **FLOW UNIT** is connected in the **direction** with the arrow indicating the fluid path.



## SETTING UP

# INJECT A VOLUME

When a **FLOW UNIT** is connected, one can **inject** a certain **volume** into the microfluidic set-up. To do so, select "*Injection method*" in the menu.

1. Turn the dial to set the "*Injection flow rate*" to the desired **injection speed**.
2. Choose "*Target volume*" to inject a **precise volume**, or "*Target time*" to run the injection over a **precise duration**.
3. Once confirmed, the "*Operation window*" will look like the examples shown.

The **Flow EZ™** or **Push-Pull** is ready to inject. Press "*Start*" to begin.

Injection flow-rate	
5.00 <span style="border: 1px solid black; padding: 2px;">1</span>	
μL/min	
Target volume	Target time
<span style="border: 1px solid black; padding: 2px;">2</span>	
Back	OK

The "*Injection method*" described is **only available** when the **Flow EZ™** or **Push-Pull** is in **stand-alone** mode. When connected to a **PC**, the injection operations need to be initiated by **Fluigent software**.

Qmeas	H2O
0.00	
μL/min	
M	
Volume :	0.0 μL
Target :	200 μL
Time :	0
Cancel	Start

**Example where 200μL is set as the target volume**

..... 3 .....

Qmeas	H2O
0.00	
μL/min	
M	
Volume :	0.0 μL
Time :	0
Target :	1:20
Cancel	Start

**Example where 1:20 min is set as the target time**

## FLOW RATE SETTINGS

**Response time** reflects how fast the **pressure controller regulates** the flow to match the **flow rate order** defined by the user.

By default, the response time is set to **2 seconds**. In some circumstances where a **smoother response** is preferred, one can **set a longer response time**.

To do so, select "*Flow rate config*" in the menu

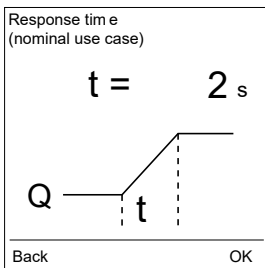

The response time is valid for many microfluidic set-ups. However, in some complex fluidic set-ups (large volume reservoirs, high fluid viscosity, etc.), the actual response time may vary.

Turn the dial to set a longer response time (between **2 seconds** and **1000 seconds**)

This setting is applied to all flow-related operations. For example, if one sets a longer response time, the flow rate transition will be smoother both in flow rate control and in injection.

## SETTING UP

# LIQUID TYPE

The type of liquid is **set manually** using the menu. Selecting the corresponding liquid type makes the flow rate measurements more **accurate**:

For **water-based** solutions: select "*H2O*" (water)

For **oil-based** solutions: select "*iPA*" (isopropanol)

### Note:

In the case of range **M FLOW UNIT**, additional liquid types are possible:

- **HFE** for HFE 7500/Novac
- **FC40**
- **Oil** for mineral oil, calibrated for Sigma Ref M8410

Some older **FLOW UNIT** models support only "*H2O*" as liquid type, therefore the liquid type selection may **not be available**.

# SYSTEM EXPANSION

## CREATING A MULTI-CHANNEL CONFIGURATION

The **Flow EZ™** and **Push-Pull** have a **hot plug & play** feature:  
One can **add or remove** a module **while the device is running**.

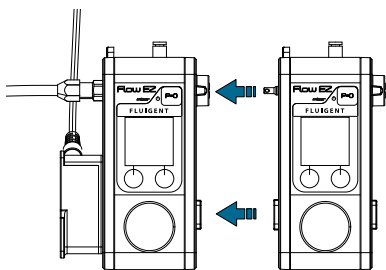

■ Add a channel

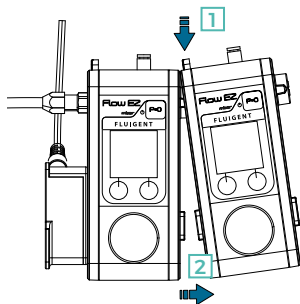

■ Remove a channel

The power and pressure supply are **automatically passed** to the newly added pressure controller. Up to **8 modules can be stacked** within one chain. (**Link** and **Adapt** modules can be added to those 8)

### MIXING DIFFERENT PRESSURE RANGES

If the ranges have the **same required pressure supply**, one can connect them by **directly lining up** the modules.

- 1 1000 mbar range Required supply pressure: 1100 mbar
- 2 1000 mbar range Required supply pressure: 1100 mbar
- 3 345 mbar range Required supply pressure: 1100 mbar

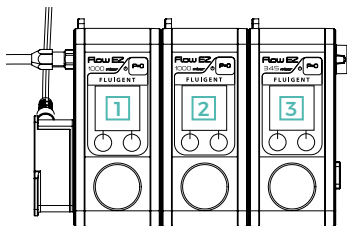

**Note:** In this configuration, You can connect up to **8 Flow EZ™** or **Push-Pull** considering they all require the **same pressure supply** (1100 mbar).

However, if a **Push-Pull** is integrated, it needs to have a **vacuum supply** in order to perform negative pressure orders.

A **Push-Pull** cannot be stacked in with a **negative FlowEZ™**

Flow EZ™ range (mbar)	Required pressure supply (mbar)
7000	7100
2000	2100
1000	1100
345	150
69	
25	
-25	
-69	
-345	-800
-800	

### LINEUP™ ADAPT

If the ranges have **different required supply pressures**, one can still have them in the same chain by inserting an **Adapt** module between them.

The **LineUp™ Adapt** is a manual pressure regulator, it **reduces the supply pressure** passed from the left side to the lower supply pressure needed for the **Flow EZ™** or **Push-Pull** on the right side.

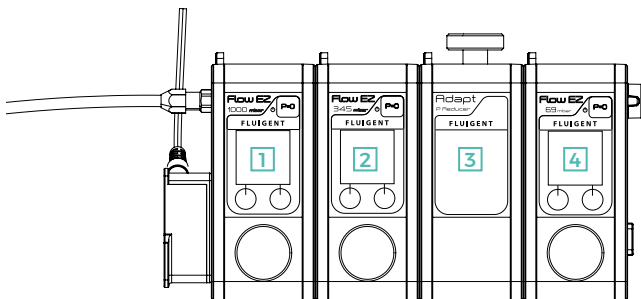
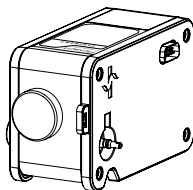

- 1 1000 mbar range Required supply pressure: 1100 mbar
- 2 1000 mbar range Required supply pressure: 1100 mbar
- 3 Adapt module Pressure reducer sold separately
- 4 69 mbar range Required supply pressure: 150 mbar

The **Flow EZ™** are ordered from **left to right** with decreasing pressure supply requirements, the **LineUp™ Adapt** ensures the pressure reduction.

# COMPUTER CONNECTION

## LINEUP™ LINK

The **LineUp™ Link** allows to connect the **Flow EZ™** or **Push-Pull** to a computer.

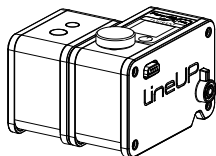

The **Link** allows the pressure controller to benefit full advanced functionalities from **Fluigent's software suite**.

- **MAT** (Microfluidic Automation Tool) for sequence automation
- **A-i-O** (All-in-One) for monitor and live control
- **SDK** (Software Development Kit) for developing custom applications

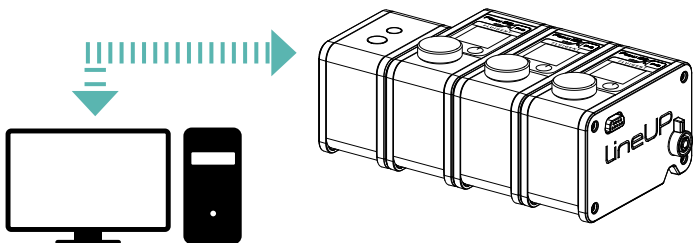

One can connect up to **8 pressure controller modules** in a chain **with or without** a **LineUp™ Link** module.

# SHUTDOWN PROCEDURE

Before disconnecting any **FLOW UNIT**, please be sure to clean it with appropriate solvent detailed in the **cleaning protocols**. Doing so will prevent any blockage and prolong its service life.

1 **Press and hold** (for a few seconds) the " $P=0$ " button in order to:

- Release the residual pressure from the system
- Put the device into "*sleep mode*"

2 **Disconnect** the **power supply** and the **pressure supply** from the system.

Always press the " $P=0$ " button **before disconnecting** the power supply. **Failure** to do so can result in **unwanted pressure applied** to the fluidic set-up.

3 **Disconnect** all pneumatic tubing by **pressing the ring inward** while **pulling the tubing outward**.

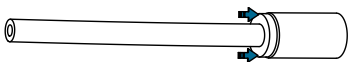

Press the ring inward



Pull the tubing outward



# ADDITIONAL FEATURES

One can use the **Flow EZ™** or **Push-Pull** in **different positions**:

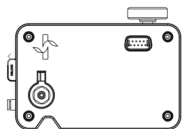

Horizontal

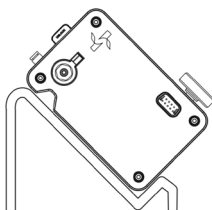

Angled

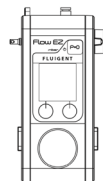

Vertical

Use the "**Chain to Chain Kit**" (sold separately) to give more flexibility when placing the multichannel configuration on the lab bench.

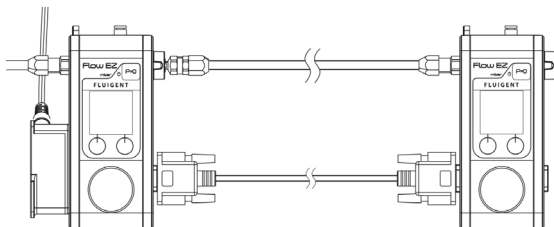

# FREQUENTLY ASKED QUESTIONS

The **Flow EZ™** or **Push-Pull** cannot achieve the **requested pressure** or **flow rate**, what should I do?

1. Verify the set-up is **air tight** and there are **no leaks**.
2. Verify that the **pressure supply** is providing the **required pressure** (**Flow EZ™** or **Push-Pull** cannot provide an outlet pressure greater than supplied pressure).
3. If the **flow rate command** cannot be achieved, verify that the fluidic path is **not blocked**.

Why has the **Flow EZ™** or **Push-Pull** stopped responding to **pressure requests** (and a similar window can be seen)?

Pmeas
230.0
Inlet = 417 mbar
Pcmd
230.0
STOPPED mbar
UNLOCK Menu

When the supply (inlet) pressure is **out of the range** during operation, the **Flow EZ™** or **Push-Pull** will stop regulating the pressure and the "Operation window" will **lock** (as seen on the left)

**Press** the "UNLOCK" button (left button) and "Inlet pressure check window" will be seen.

It will **assist** in **adjusting the inlet pressure** to the required value)

## FREQUENTLY ASKED QUESTIONS

I bought my **FLOW UNIT** long before I bought my **Flow EZ™** or **Push-Pull**, but when I connect it, my device says it is "*Not Supported*". Why is that?

Some older **FLOW UNITS** are **not supported** by the **Flow EZ™** or **Push-Pull**. In this case, please contact Fluigent at [support@fluigent.com](mailto:support@fluigent.com)

Can I use the **LineUp™ Push-Pull** even if one of the two inlets is not supplied, as a regular positive or negative **Flow EZ™**?

The **LineUp™ Push-Pull** can be used as a **Flow EZ™ 1000 mbar** and as a **Flow EZ™ vacuum -800 mbar** independently. A **positive pressure** should always be applied for use. The **vacuum one** is not needed unless one wishes to apply **negative pressure values**.



For **more FAQs**, please visit [www.fluigent.com](http://www.fluigent.com)



For **tutorial videos** about the **LineUp™ series**, please visit our **YouTube channel**: [Fluigent](#)

# WARRANTY TERMS

## What this warranty covers

This warranty is granted by Fluigent and applies in all countries. The Fluigent product is guaranteed for one year from the date of delivery at the laboratory against defects in materials and workmanship. If found to be defective within the warranty period, the Fluigent product will be repaired or replaced free of charge.

## What this warranty does not cover

This warranty does not cover routine maintenance, or damage resulting from the failure to maintain the product in accordance with instructions provided by Fluigent. This warranty also does not cover damage that arises from accidental or intentional misuse or abuse, alteration or customization, or repairs by unauthorized persons.

## How to get service

If there is a problem, please contact the Fluigent sales office from where one purchased the product(s). Arrange a mutually convenient time for Fluigent service representative to discuss and find a solution to fix the issue. Repairs will be made remotely whenever possible. If more action is needed, the system will need to be sent back to Fluigent offices (for no additional cost, only if it is under warranty).

## Warranty conditions

- Do not open any LineUp™ series device
- Do not use cables and power supplies other than the one provided by Fluigent
- Prevent foreign objects or liquids from entering the device
- Do not place the product in an unstable location
- Respect the temperature compatibility (from 5°C to 40°C)
- For positive ranges of pressure, please do not apply above 8 bar
- For negative ranges of pressure, please do not apply any positive pressure
- Use a filtered (<10µm) and dried air supply
- Prevent heavy objects from falling on the device
- Prevent any corrosive liquid from coming in contact with the device

# TECHNICAL SUPPORT

Still have questions? E-mail us at:

[support@fluigent.com](mailto:support@fluigent.com)

Or call our technical support team directly



**Fluigent S.A.S** +33 1 77 01 82 65

**Fluigent Inc.** +1 (978) 934 5283

**Fluigent GmbH** +49 3641 277 652

For a fully detailed FAQ for all Fluigent products, please visit:



<http://www.fluigent.com/faqs/>

Interested in Fluigent products ?

To view the **complete Fluigent product line** and **application notes**:



<http://www.fluigent.com>

For **commercial requests**, please e-mail:



[sales@fluigent.com](mailto:sales@fluigent.com) or your local office

For **tutorial videos** about the **LineUp™ series**, please visit Fluigent on YouTube



**Fluigent**

# Volume and Resistance for tubing with different ID (Inner Diameter)

Place your tubing on the page for a quick reference (printed in real size)

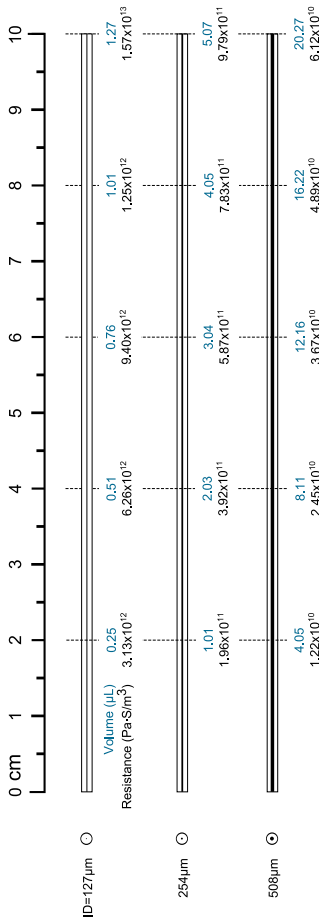

## OD (Outer Diameter) identification

Printed in real size



1/16" (1.6mm)



1/32" (0.8mm)

## Units Conversion

1psi = 68.95 mbar

1mbar = 1.45 X 10<sup>-2</sup>psi

1inch = 2.54 cm

1cm = 0.39 inch





**VERSION  
MAR. 2020**

