

PLGA MICROPARTICLE SYNTHESIS

ABSTRACT

When PLGA is used as an active pharmaceutical ingredient carrier it is important to produce highly monodispersed particles for drug release reproducibility. The most common production process of PLGA particles is solvent based and can involve hazardous solutions. Ethyl acetate is preferred as it shows better biocompatibility than other conventional solvent such as dichloromethane. We present here a novel PLGA microparticle production station based on a new droplet production technology (RayDrop system designed by Secoya) and high precision pressure pumps (Flow EZ™, Fluigent). The station is adapted for working with ethyl acetate solvent and shows outstanding monodisperse particle production. We present an overall characterization of the device including phase diagrams for several PLGA concentrations. This station is particularly suitable for researchers who want to test different API encapsulation conditions with highly reproducible results.

This application note was made in collaboration with Adrien Dewandre at Transfers Interfaces and Processes (TIPs) lab, Université libre de Bruxelles (ULB).

For more information visit the website: <https://tips-ulb.be>

INTRODUCTION

In recent years, biodegradable microspheres/microparticles have gained widespread importance in the delivery of bioactive agents [1]. The copolymers of Poly (D, L-lactic-co-glycolic acid) (PLGA)/poly (lactic acid) (PLA) microparticles are one of the most successful new drug delivery systems (DDS) in labs and clinics. Because of good biocompatibility and biodegradability, they can be used in various areas, such as long-term release systems, vaccine adjuvant, and tissue engineering [2]. Using PLGA/ PLA has demonstrated longer and better efficiency, reduction of administration frequency [3–5] by many administration routes, including subcutaneous injection, intramuscular injection, oral administration, pulmonary administration [6,7], and ocular administration [8].

PLGA/PLA microparticles can be used to encapsulate hydrophobic as hydrophilic therapeutics drugs and allowing for reduced dosing frequency and less potential toxicity. [9–11] In PLGA microparticle production for drug release and delivery, microparticle size is a paramount parameter. Indeed, the microparticle size is directly related to the microparticles degradation rate as well as the drug release rate [12].

Although PLGA microparticle synthesis appears to be a successful drug delivery system, the current processes and tools to produce PLGA microparticles have many limitations such as wide microparticle size distribution, poor repeatability, and aggressive preparation conditions [2].

To solve these problems, microfluidics, and more exactly droplet-based microfluidics, offers an efficient method for improvement. Droplet based microfluidics is a powerful tool which enables of micrometric monodispersed droplet generation and manipulation.

APPLICATION NOTE

Microfluidic droplet size control and generation rate allows highly monodispersed droplet productions opposed to other batch emulsion methods and provides an “In-line” continuous droplet production process. There are many different PLGA particle production methods such as solvent extraction, solvent evaporation or solvent exchange. In all cases, the nature of the solvent is an important parameter that must be taken into account. Indeed, it affects the PLGA precipitation time and must be biocompatible with the active agent.

Currently in every microfluidic system for PLGA microparticles production highlighted by researchers, dichloromethane is the most used and widespread solvent. Nevertheless, some researchers have highlighted some limitations of this solvent due to its potential toxicity [13]. Ethyl acetate has been considered as an alternative dispersed solvent useful in preparing PLGA microspheres because of its properties less hazardous. It is thus more suitable for biological applications [14]. Moreover, due to high solubility, ethyl acetate allows a reduced PLGA precipitation time.

According to the U.S. Department of Health and Human Services Food and Drug Administration, Center for Drug Evaluation and Research (CDER), Center for Biologics Evaluation and Research (CBER) classification, dichloromethane is recognized as a class 2 solvent whereas ethyl acetate is class 3 which makes it more suitable for biological applications. Even though, some end-user production devices using ethyl acetate are available on the market but they all present limitations for PLGA microparticles, which are released with the new microfluidic device presented in this application note.

DESCRIPTION

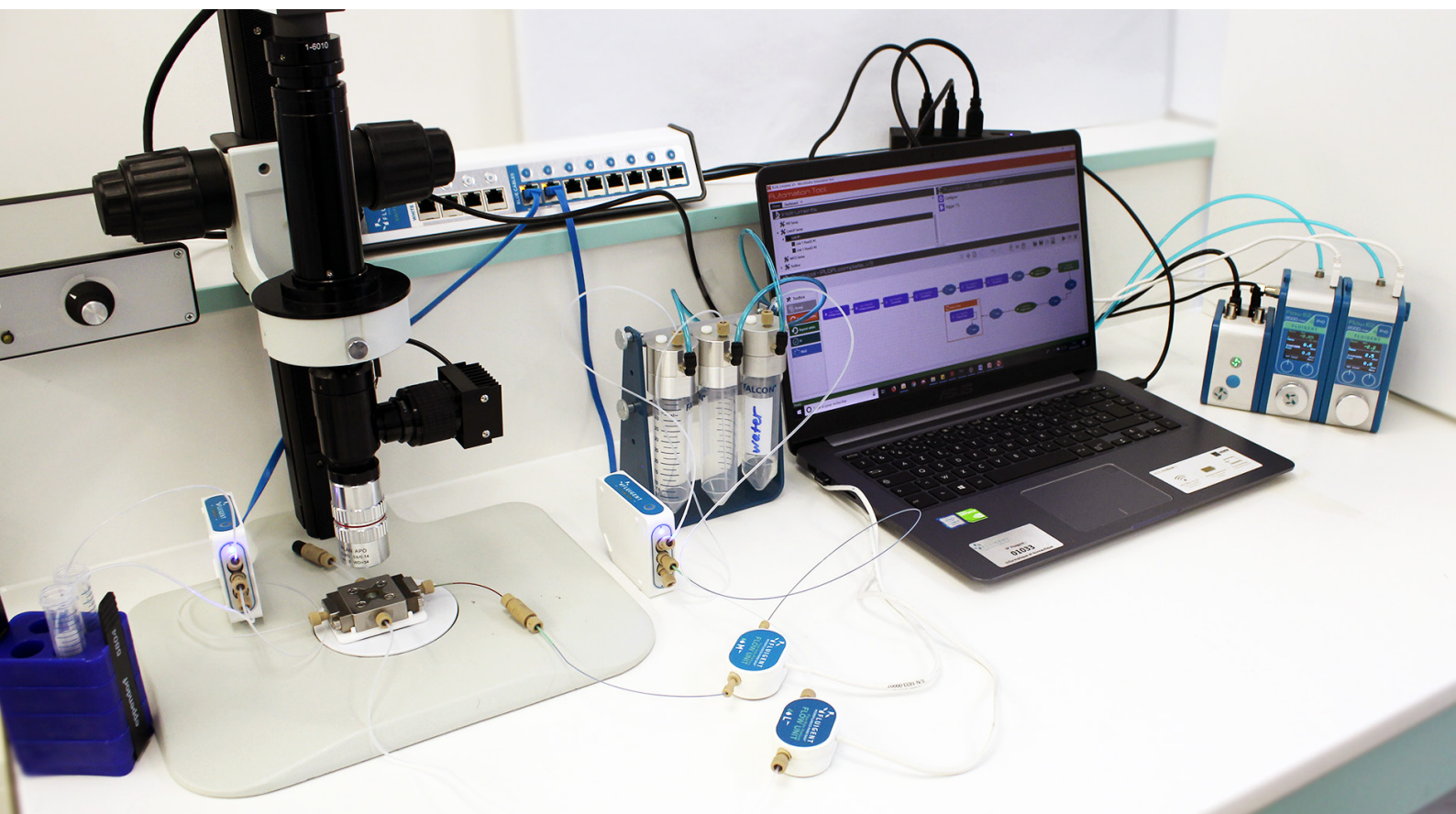
Fluigent presents a new microfluidic device and system for PLGA microparticle synthesis

Figure 1: PLGA microparticle production station

All the products currently available in the market have critical drawbacks. Fluigent in collaboration with Secoya, a spin-off of the Université libre de Bruxelles, has developed a new breakthrough technology leading to outstanding particle size monodispersity and production flexibility.

In this application note we will describe a novel platform and protocol to use ethyl acetate at different concentrations for PLGA polymerization and continuous synthesis. This application note characterizes the Fluigent solution for generating PLGA microparticles. The monodispersity and solvent extraction time are measured and discussed. Wide and detailed phase diagrams for various PLGA concentration are provided showing parameters for manipulating droplet size and frequency.

For any additional information, please contact us by email: contact@fluigent.com or consult our website: www.fluigent.com

APPLICATION NOTE

MATERIALS AND METHODS

Reagents

- **Priming fluid:** Ethyl acetate filtered with 0.2 μm pore filter and used without further modification (Sigma Aldrich, CAS Number: 141-78-6)
- **Droplet fluid:** Resomer® RG 753 S, Poly(D,L-lactide-co-glycolide) ester terminated, Lactide: Glycolide 75:25 is dissolved in ethyl acetate at room temperature by stirring over the course of an hour (Sigma aldrich,CAS Number: 26780-50-7).
- **Continuous phase:** 2 % (w/v) Poly (vinyl alcohol) (PVA) surfactant in water is filtered with a 0.2 μm pore filter (Sigma Aldrich,CAS Number: 9002-89-5).

Droplet generation experimental set-up

PLGA microparticle production station, full pack

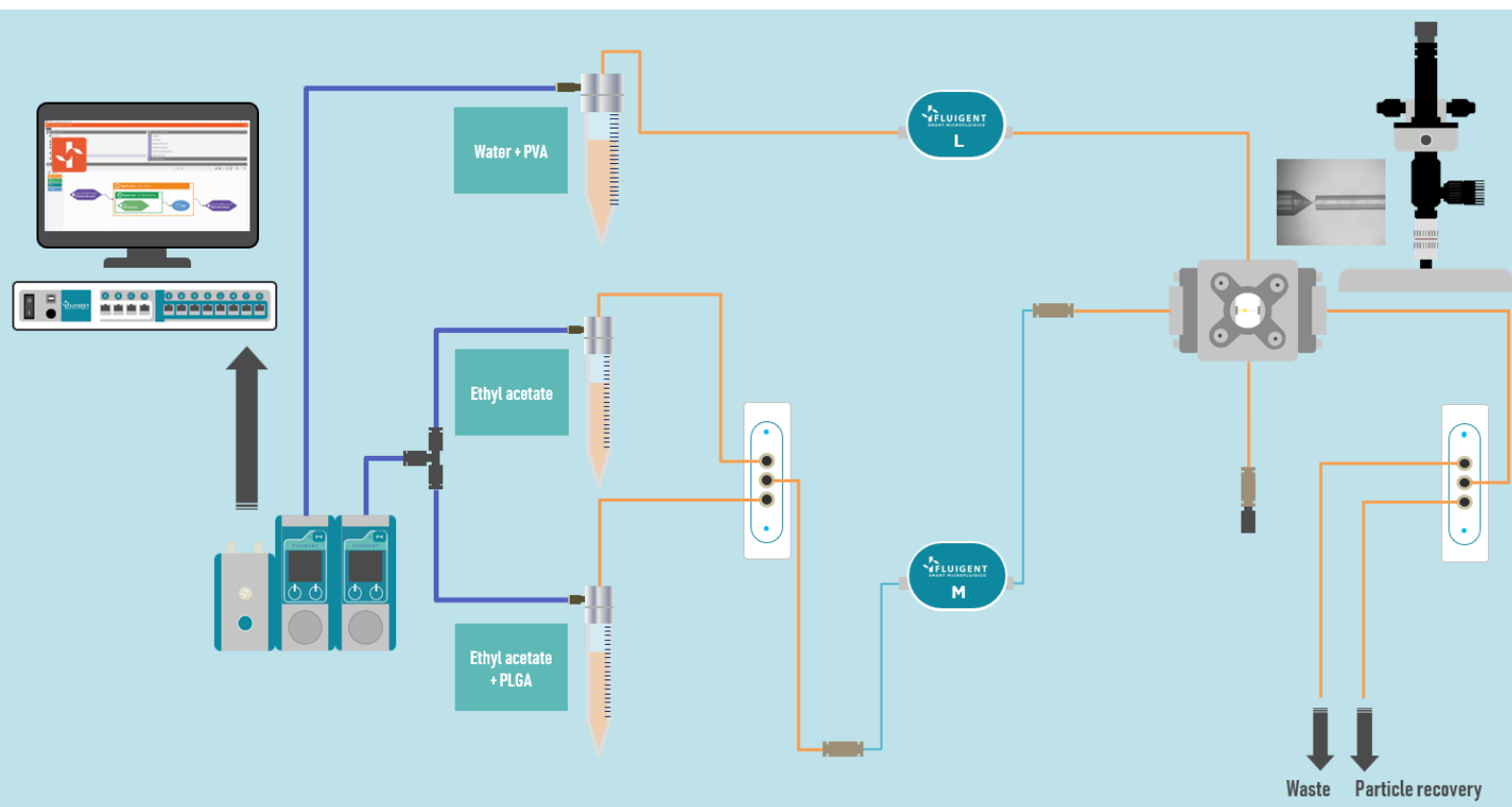


Figure 2: Schematic of PLGA microparticle production station set-up, full pack

The droplet generation set-up is illustrated in the previous picture. Two different pressure controllers (Flow EZ™, Fluigent) are used to handle fluids. A 3/2 valve (2-SWITCH™, Fluigent) valve is used to switch between pure ethyl acetate and PLGA dissolved in ethyl acetate and a second valve is also used in particle production output to switch between a waste and recover sample (see the detailed protocol in the attachment down page). Two FLOW UNIT sensors are used to monitor and control the internal and external phases flow rates during the run. The new, innovative RayDrop system is used to generate PLGA droplets.

Droplet monitoring and Analysis

To observe droplet generation an Inverted microscope (Nikon, Eclipse Ti 2) coupled with High speed camera (Nikon, PhotronFastcam) have been used. For droplet sizes analysis the software PhotronFastcam Viewer has been used. To estimate droplet frequency the following formula has been used. Droplet rate (Hz) = Droplet phase flow rate (μL/s) / Droplet volume (μL).

Microparticle Precipitation

Once droplets are generated, the solvent inside the microparticles in the presence of the continuous phase will continuously diffuse out of the droplet. With solvent diffusion outside of the droplet the PLGA concentration will increase and precipitate to form a solid microparticle smaller than the droplet.

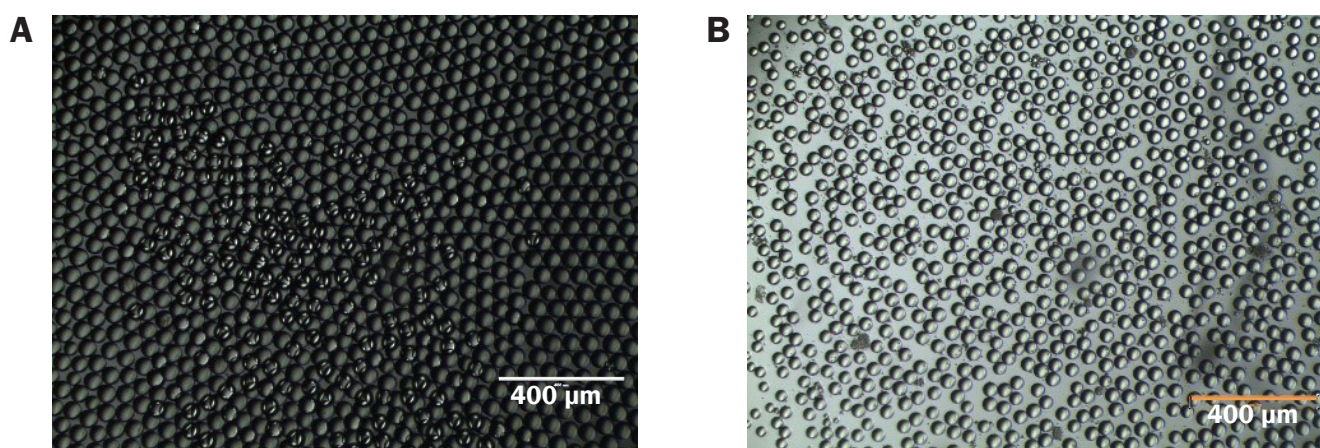


Figure 3: Particle shrinking during solvent evaporation: A) Particle size just after droplet formation B) Particle size after few seconds

APPLICATION NOTE

Microparticle Recovery

Microparticles are recovered in a vial containing the continuous phase: water with 2% PVA. The microparticle size and monodispersity are determined under a microscope. To do so, collect a small sample by placing the outlet tubing directly on a glass cover slip.

RESULTS

Dispersed phase: 2% (w/v) PLGA in ethyl acetate

Continuous phase: 2% (w/v) PVA in water

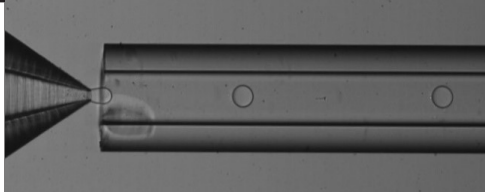
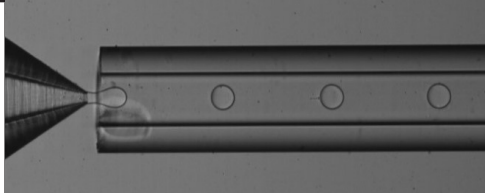
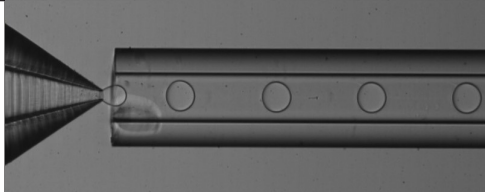
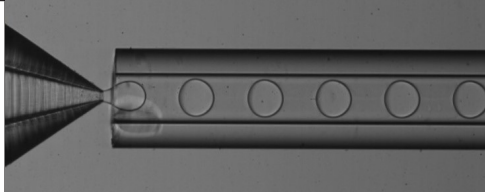
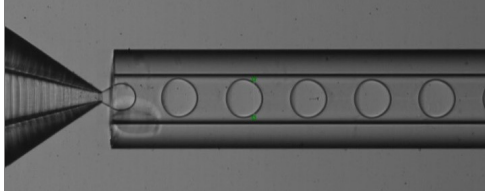
Dispersed phase / Droplet phase		Continuous phase		Droplets		Picture	Micro-particles	Quantity
P (mbar)	Q (μL/min)	P (mbar)	Q (μL/min)	Diameter (μm)	Rate (Hz)		Diameter (μm)	Quantity (mg/h)
492	3	1348	100	64	364		19	4.7
592	5	1348	100	68	506		20	7.65
893	10	1374	100	76	725		26	24.1
1052	12.5	1400	100	80	778		27	29.1
1222	15	1454	100	80	933		27	35

Figure 3: Table showing how flow-rate changes affect PLGA particle size and production rate

After generation, a microparticle size population has been analyzed to determine microparticles monodispersity at 1%. The monodispersity has been analyzed on a microparticle population (around 100 microparticles). The flow rates have been adapted to generate 20 μm diameter particle size (cf phase diagram).

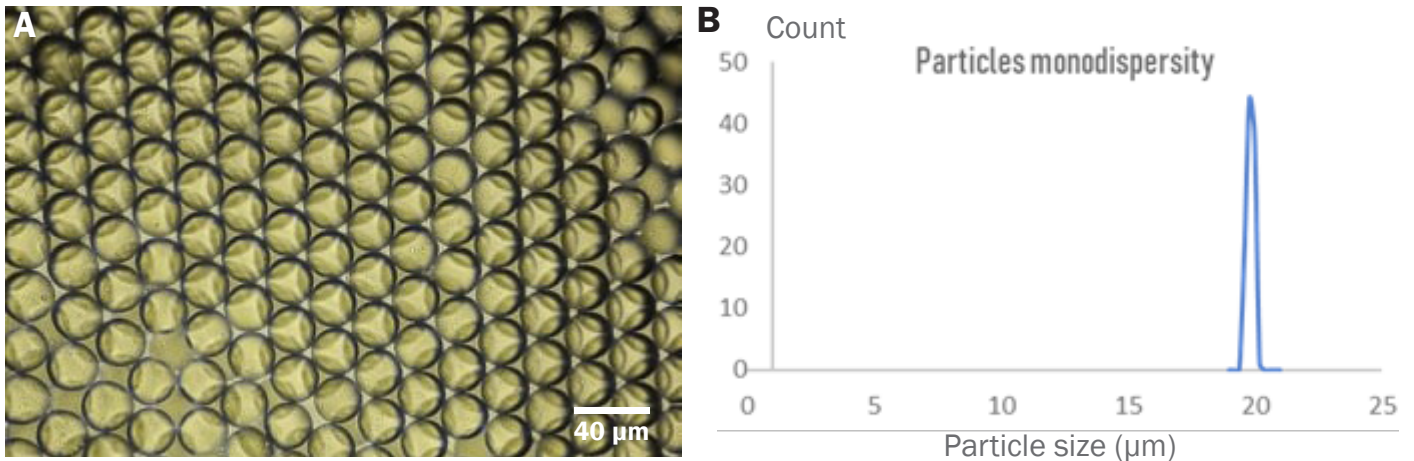


Figure 5: Particle size distribution: A) Microscope observation of PLGA microparticles just after the generation B) Particle monodispersity graph

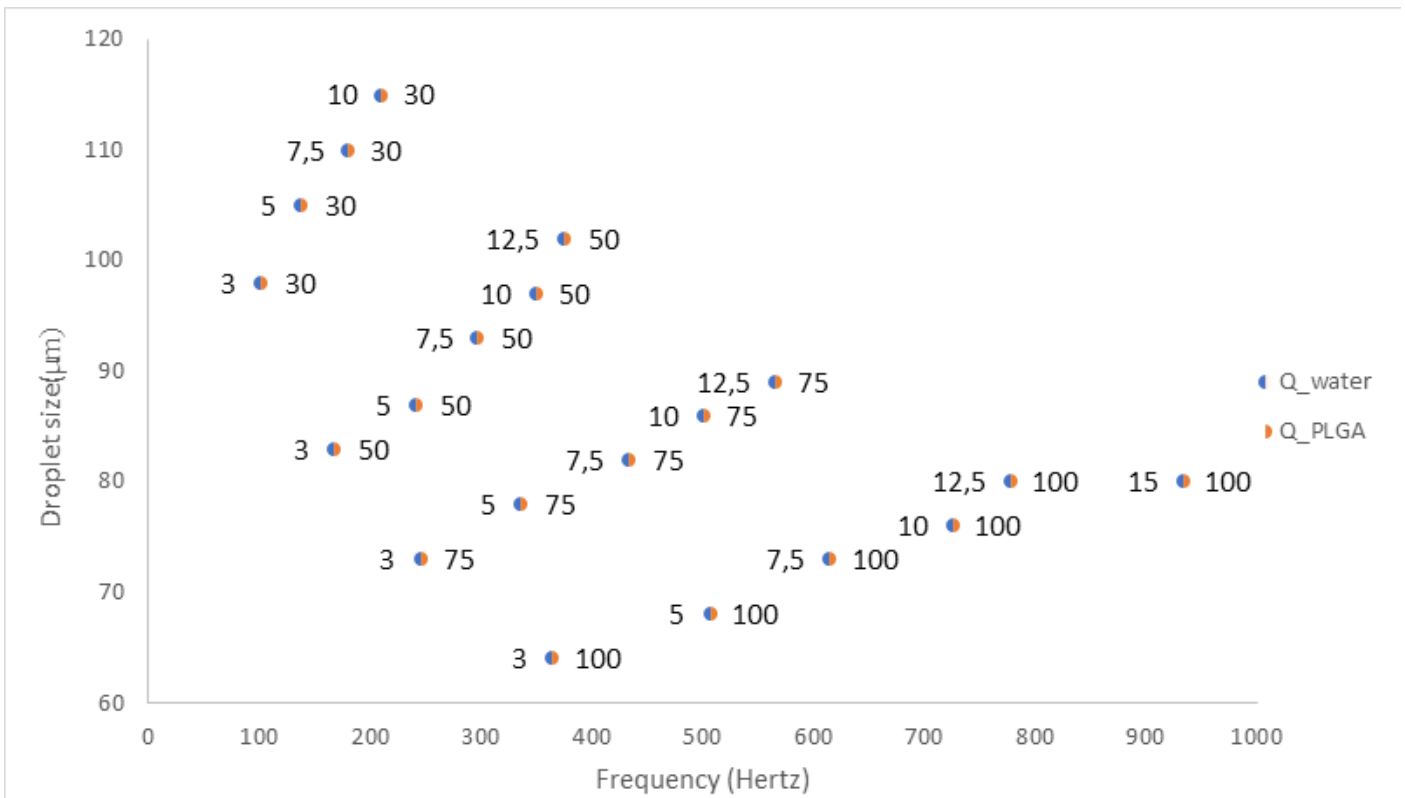


Figure 6: Droplet size diagram with 2% (w/v) PLGA concentration

APPLICATION NOTE

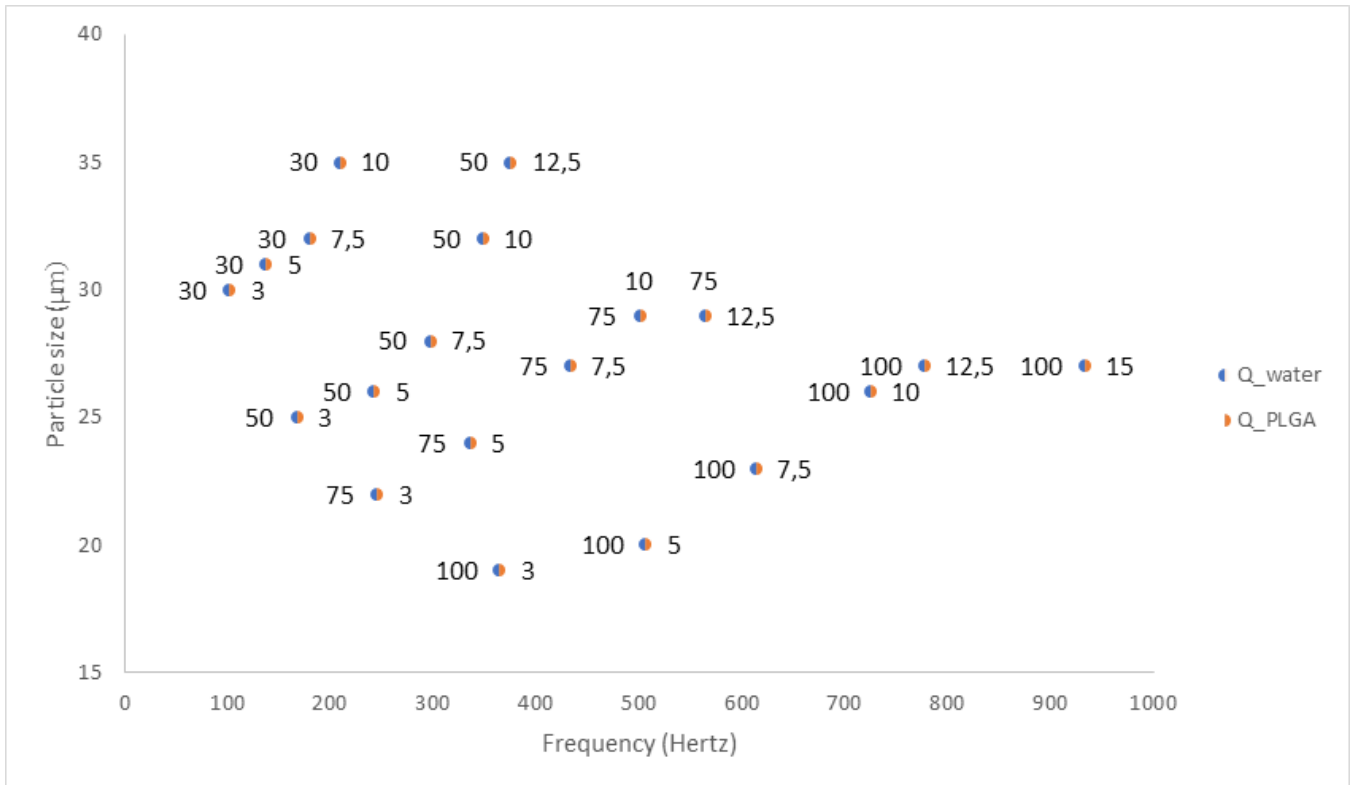


Figure 7: Particle size diagram with 2% (w/v) PLGA concentration

Results with Other Concentration

Dispersed phase: 5% (w/v) PLGA in ethyl acetate
Continuous phase: 2% (w/v) PVA in water

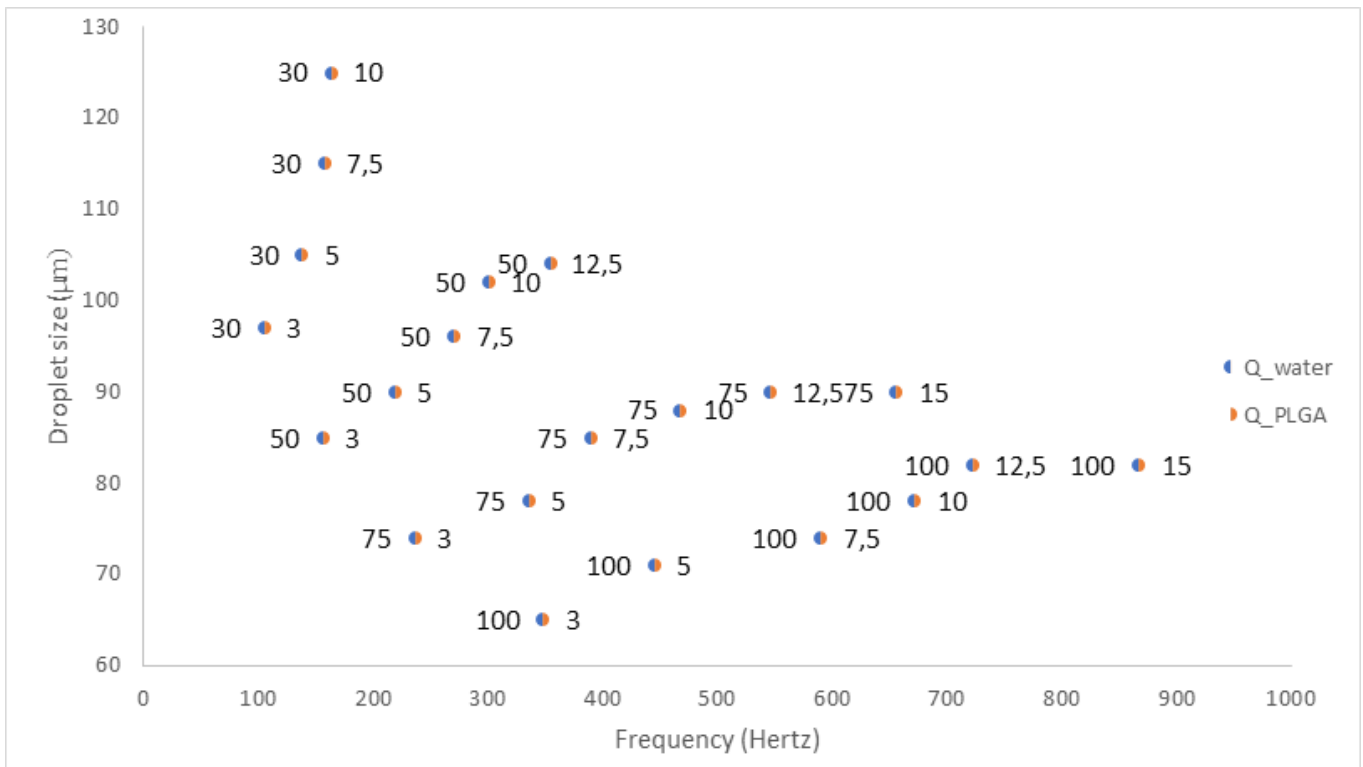


Figure 8: Droplet size diagram with 5% (w/v) PLGA concentration

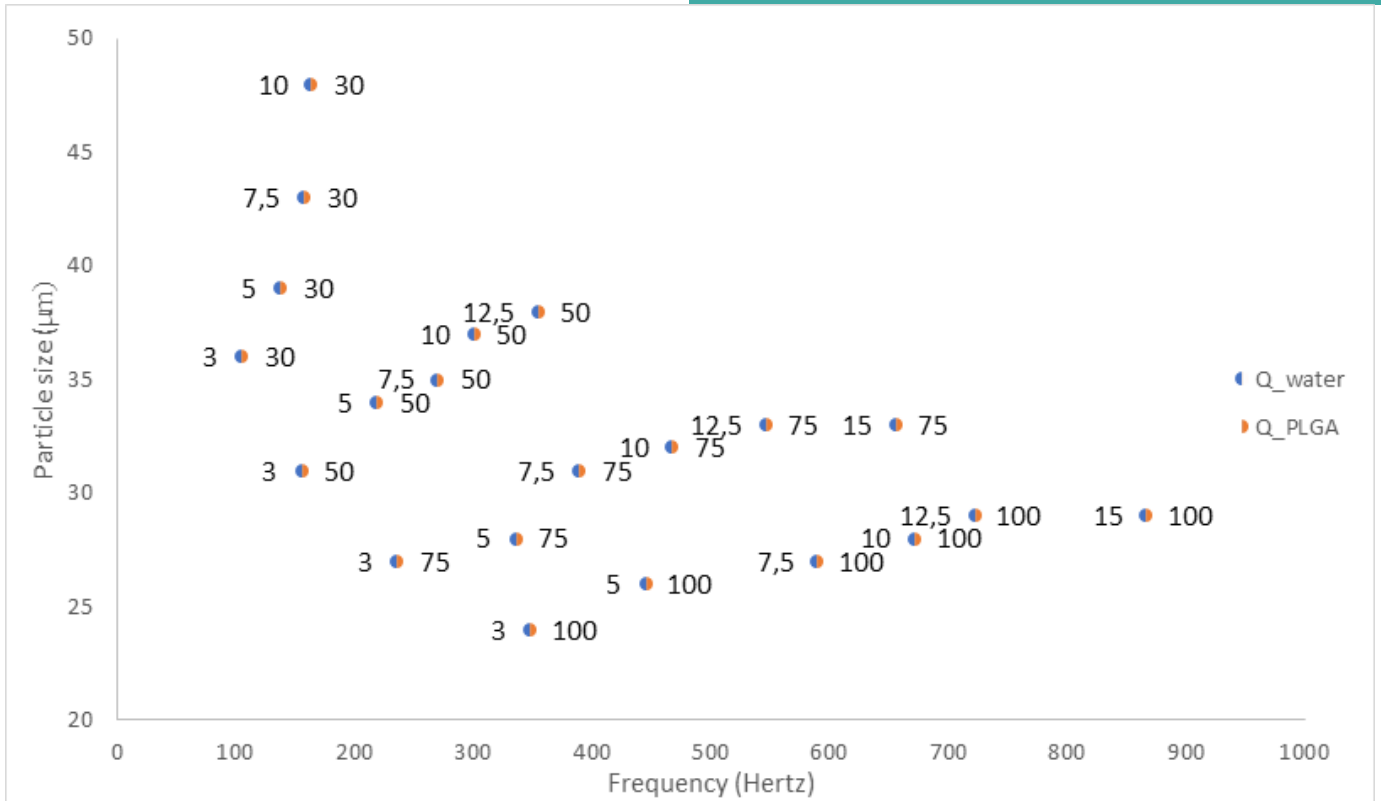


Figure 9: Particle size diagram with 5% (w/v) PLGA concentration

Dispersed phase: 10% (w/v) PLGA in ethyl acetate
Continuous phase: 2% (w/v) PVA in water

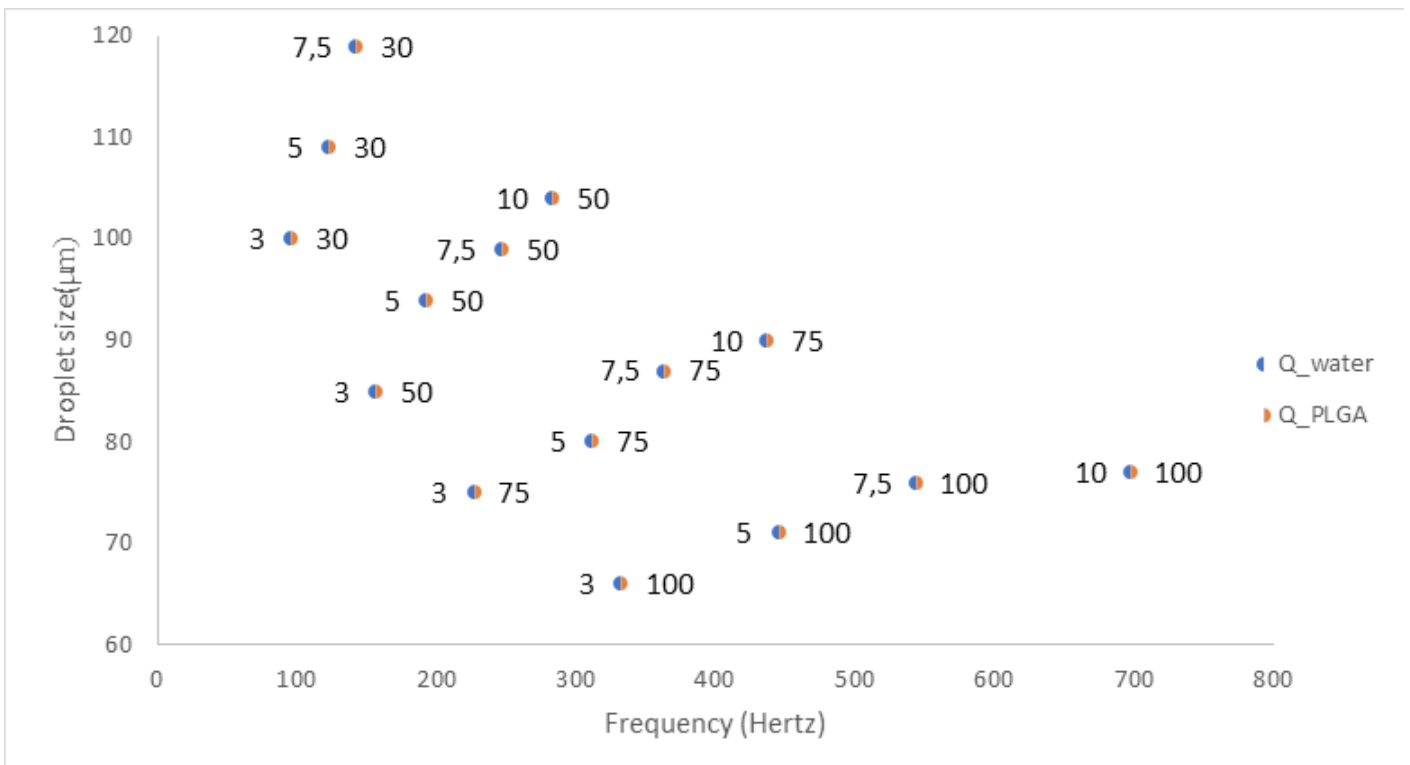


Figure 10: Droplet size diagram with 10% (w/v) PLGA concentration

APPLICATION NOTE

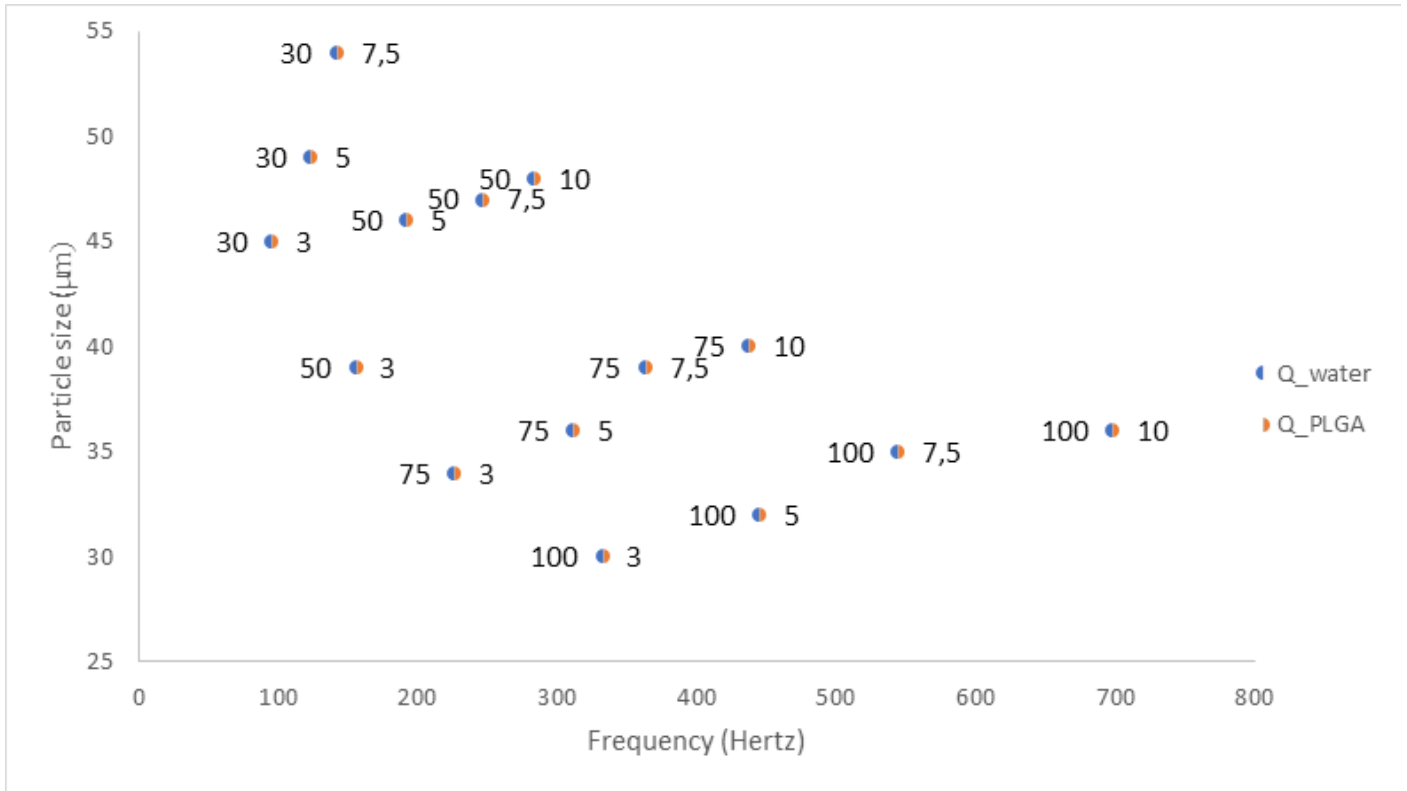


Figure 11: Particle size diagram with 10% (w/v) PLGA concentration

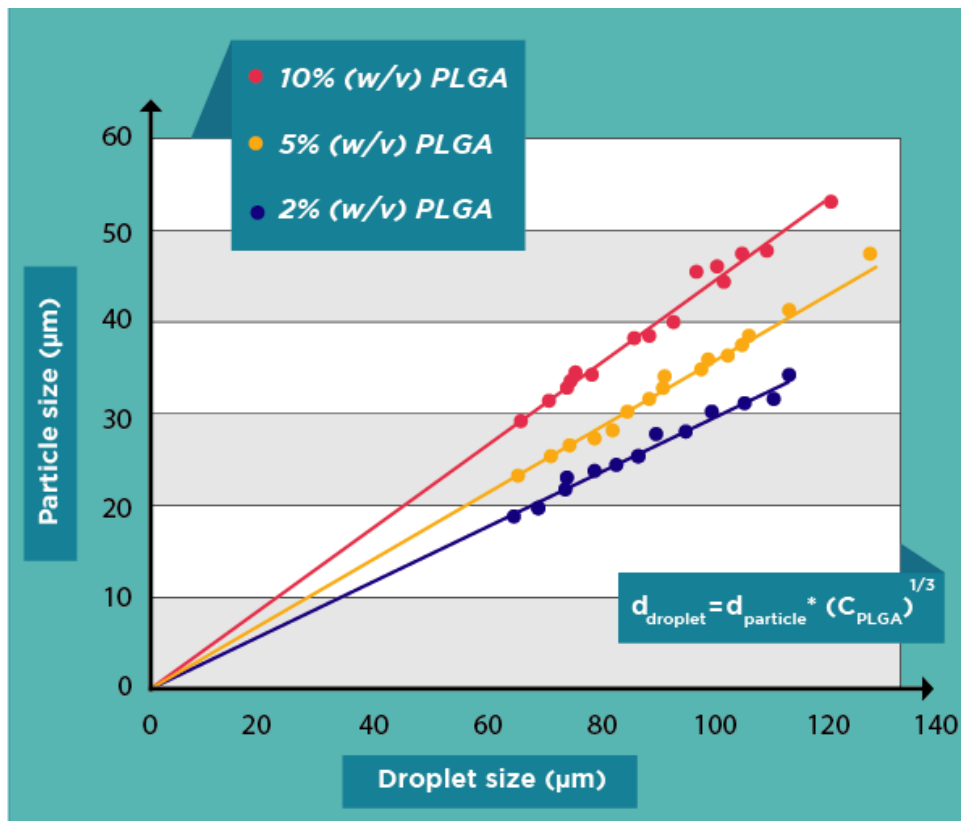


Figure 12: Particle shrinking for different PLGA concentration

CONCLUSION

PLGA microparticles ranging from 15 to 50 μm in diameter have been successfully generated. The PLGA microparticle production station allows an excellent reproducibility and significantly improved monodispersity ($\text{CV} < 2\%$) as compared to other methods on the market. It allows one to continuously produce PLGA microparticles without unwanted interruption for long term experiments. The versatility and protocols put in place allows for rapid startup with a short learning curve. Fluigent has developed a PLGA synthesis package to allow for a high quality and continuous production for routine experiments. It gathers all droplet microfluidic and pressure-based solution advantages to focus on the experiment and even the possibility to automate protocols for different microparticle size production.

	Traditional methods (Batch methods)	Fluigent PLGA microparticle production station
Particle size distribution	~20%	~2%
Reproducibility	Low	High
API mixing	Uneven	Uniform
Live particle size control	No	Precise
Continuous/in line production	No	Yes
	Microfluidic methods available on the market	Fluigent PLGA microparticle production station
Particle size distribution	~5%	~2%
Semi automated production	No	Yes
Ethyl acetate dedicated protocol	No	Yes
Device regeneration	No (glass chip changed when clogged)	Yes (the RayDrop can be maintained)
Connectors	Non standard, user dependant quality (leakage, blockage)	Standard fittings for better sealing

1.2 Filling the Raydrop

State

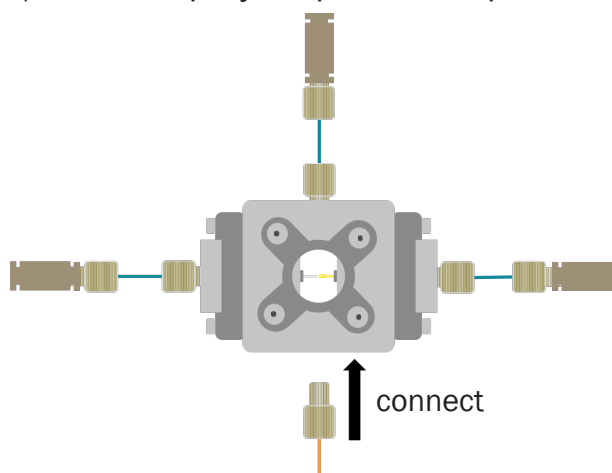
- The dispersed phase inlet is not yet connected to union before the device.
- The continuous phase channel is connected to the RayDrop.
- The output tubing is connected to the device outlet.
- The RayDrop cavity is empty.
- The first 2-SWITCH™ valve is in the ethyl acetate position.
- The second 2-SWITCH™ is in the waste position.



Steps to reproduce

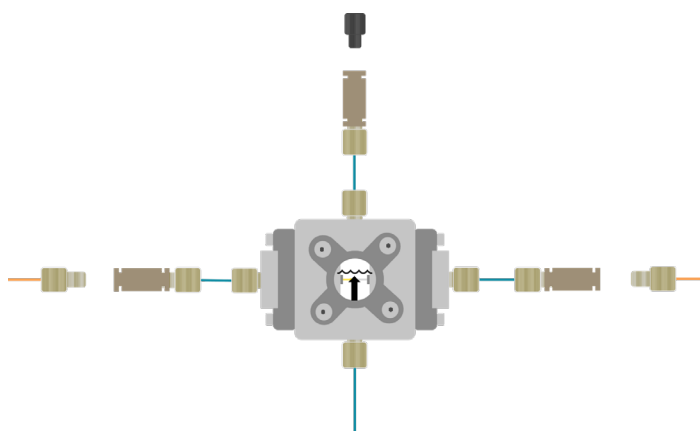
Before the first use of the RayDrop, the cavity has to be filled with the continuous phase. This operation has to be done once only. (Find a step by step detailed protocole on the *good practice guide*)

1 Connect the continuous phase



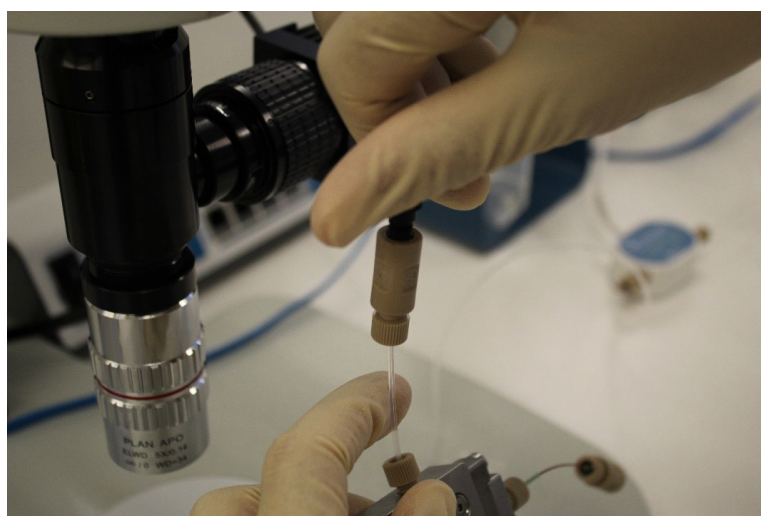
APPLICATION NOTE

2 Hold the RayDrop vertically, with the continuous phase channel on the bottom.



3 Set the flow rate to a high value (high pressure) on the continuous phase. As you can observe through the windows, the cavity is progressively filled with the continuous phase. If air bubbles are remaining in the chamber you can agitate the RayDrop to easily remove bubbles.

4 When continuous phase starts to flow from the top tubing capillary, close the purge outlet with the plug. The continuous phase is now filling both capillaries, flushing out the air trapped inside. (You can use a plug on the outlet to help flushing every channel but make sure that all tubing is flushed with continuous phase)



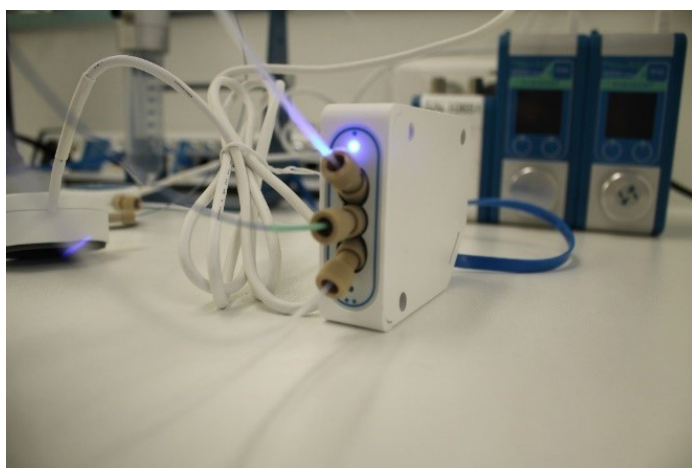
5 When there is no more air trapped into capillaries and tubings, decrease the flow rate to a low value to avoid wasting continuous phase.

2. Priming the system and generating microparticles

This part explains how to generate microparticles with the RayDrop and the station.

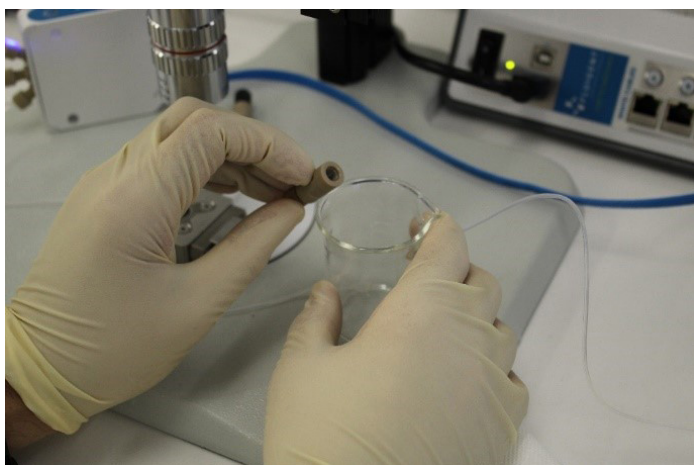
State

- The dispersed phase inlet is not yet connected to union before the device.
- The continuous phase channel is connected to the RayDrop.
- The output tubing is connected to the device outlet.
- The Raydrop cavity has been filled with the continuous phase.
- The first 2-SWITCH™ valve is in the ethyl acetate position. Make sure that you are in the right 2-SWITCH™ configuration to inject the ethyl acetate and not the PLGA yet.
- The second 2-SWITCH™ is in the waste position.



Steps to reproduce

- 1 Set the flow-rate of the continuous phase to a high value (1200mbar) until the continuous phase starts to flow from both the input and output channels.

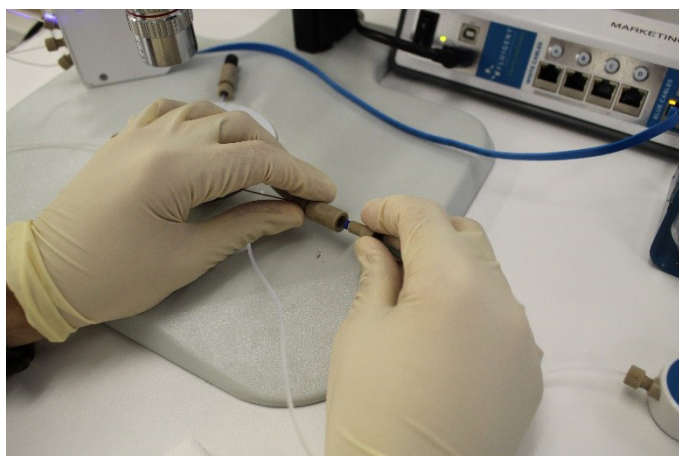


APPLICATION NOTE

2 Set the flow-rate on the droplet phase channel to a high value until you observe the ethyl acetate flowing at the tubing outlet and no more air bubbles. (100 mbar should be enough)



3 Connect the dispersed inlet to the RayDrop.



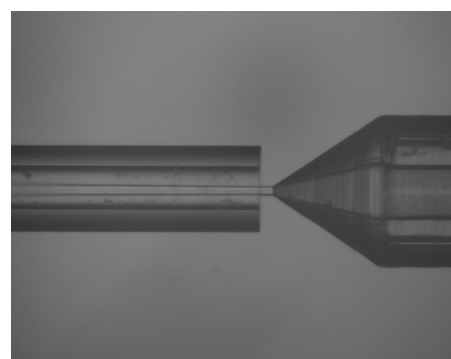
At this step, the ethyl acetate flow might change drastically and back flow could be observed

4 Increase the Ethyl acetate pressure to reach a positive flow rate (around 10 $\mu\text{l}/\text{min}$). Make sure to always have, at the beginning, at least 10 times more continuous phase than the dispersed phase.

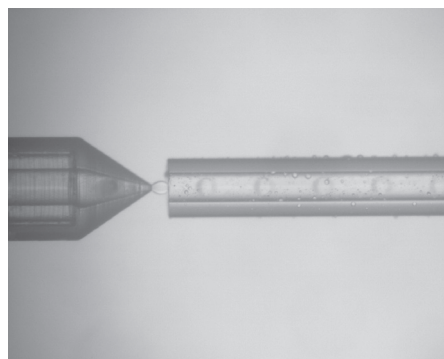
At this step:

- Adjust as needed to reach the state:
 - Water flow rate= 100 $\mu\text{l}/\text{min}$
 - Ethyl acetate flow rate= 10 $\mu\text{l}/\text{min}$
- Or use the MAT protocol if you have the Automated pack and skip all the next step.

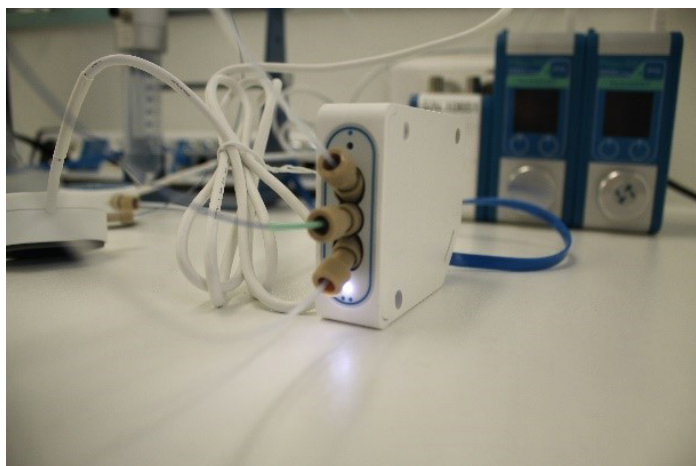
After approximatively one minute, a jetting state appears.



5 Decrease sequentially the two pressures until you observe droplet formation. Always decrease the ethyl acetate first and after decrease the continuous phase.



6 As soon as a suitable ethyl acetate droplet formation regime is reached, switch the first 2-SWITCH™ valve to allow now a flow of PLGA solution (at this step you might see the dispersed phase flow rate decreasing a bit).



7 Then wait for the PLGA solution to come into the input channel.

8 As soon as all the ethyl acetate solution is pushed out from the input channel you should be in the PLGA droplet generation state.

9 Switch the second 2-SWITCH™ to recover the microparticles generated.

10 If you need to achieve a specific size and rate of droplets, adjust the pressures to reach a certain continuous/droplet phases flow rate combination.

ATTENTION: to avoid the dispersed phase to enter in the cavity, note to always work with a continuous flow-rate at least twice the droplet flow-rate.

3. Stop generation and shutting down the experiment

This part explains how to properly stop droplet generation and avoid any channel lockage for further experiments (for a complete review of cleaning methods and current issues, please refer to the *good practise guide*)

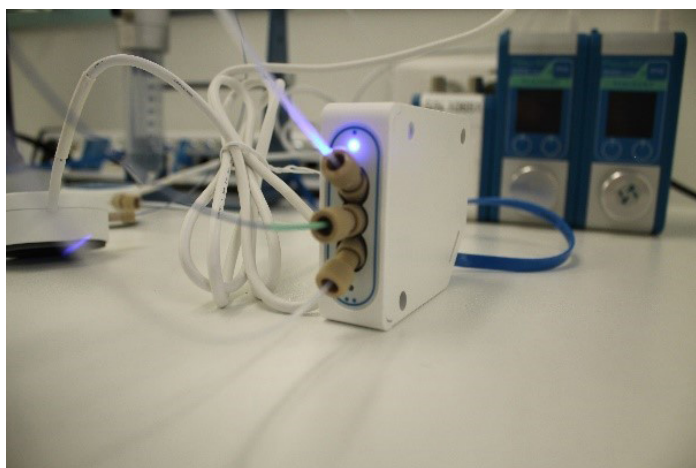
State

- The dispersed phase inlet is connected to union before the device.
- The continuous phase channel is connected to the RayDrop.
- The output tubing is connected to the device outlet.
- The RayDrop cavity has been filled with the continuous phase.
- The first 2-SWITCH™ valve is in the PLGA position.
- The second 2-SWITCH™ is in the recover position.

Steps to reproduce

1 Switch the first 2-SWITCH™ valve to the ethyl acetate position, allowing a flow of ethyl acetate (at this step you might see the dispersed phase flow rate change a bit)

2 Switch the second 2-SWITCH™ valve to the waste position



3 Wait for the ethyl acetate solution to come in the input channel.

4 As soon as all the PLGA solution is pushed out of the input channel wait a little moment to completely flush the output channel.

5 Then you can start decreasing the solvent solution flow rate and disconnect the dispersed phase input, without changing the flow rate of the continuous phase. Stop the flow of ethyl acetate once disconnected.



6 The continuous phase should now flow from the outlet and the inlet. To allow for flushing and cleaning, wait a little time to make sure that all PLGA solution is totally removed from all channel and avoid plugging for next experiment. (you can use a plug on the outlet to help flushing every channel)

7 Then you can lock everything with the plugs and set the pressures to zero.

REFERENCES

- [1] Soppimath, K. S., & Aminabhavi, T. M. (2002). Ethyl acetate as a dispersing solvent in the production of poly (DL -lactide-co-glycolide) microspheres : effect of process, 19(3), 281–292. <https://doi.org/10.1080/02652040110105319>
- [2] Qi, F., Wu, J., Li, H., & Ma, G. (2018). Recent research and development of PLGA / PLA microspheres / nanoparticles: A review in scientific and industrial aspects.
- [3] Kwak H H, Shim W S, Choi M K, Son M K, Kim Y J, Yang H C, Kim T H, Lee G I, Kim B M, Kang S H, et al. Development of a sustained-release recombinant human growth hormone formulation. *Journal of Controlled Release*, 2009, 137(2): 160–165
- [4]. Kim B S, Oh J M, Hyun H, Kim K S, Lee S H, Kim Y H, Park K, Lee H B, Kim M S. Insulin-loaded microcapsules for in vivo delivery. *Molecular Pharmaceutics*, 2009, 6(2): 353–365
- [5]. Kwak H H, Shim W S, Hwang S, Son M K, Kim Y J, Kim T H, Yoon Z H, Youn H J, Lee G I, Kang S H, et al. Pharmacokinetics and efficacy of a biweekly dosage formulation of exenatide in Zucker diabetic fatty (ZDF) rats. *Pharmaceutical Research*, 2009, 26(11): 2504–2512
- [6]. Gaspar M C, Gregoire N, Sousa J J S, Pais A A C C, Lamarche I, Gobin P, Olivier J C, Marchand S, Couet W. Pulmonary pharmacokinetics of levofloxacin in rats after aerosolization of immediate-release chitosan or sustained-release PLGA microspheres. *European Journal of Pharmaceutical Sciences*, 2016, 93: 184–191
- [7]. Feng T S, Tian H Y, Xu C N, Lin L, Xie Z G, Lam M H W, Liang H J, Chen X S. Synergistic co-delivery of doxorubicin and paclitaxel by porous PLGA microspheres for pulmonary inhalation treatment. *European Journal of Pharmaceutics and Biopharmaceutics*, 2014, 88(3): 1086–1093
- [8]. Salama A H, Mahmoud A A, Kamel R. A novel method for preparing surface-modified fluocinolone acetonide loaded PLGA nanoparticles for ocular use: In vitro and in vivo evaluations. *AAPS PharmSciTech*, 2016, 17(5): 1159–1172

- [9]. Qi F, Wu J, Fan Q Z, He F, Tian G F, Yang T Y, Ma G H, Su Z G. Preparation of uniform-sized exenatide-loaded PLGA microspheres as long-effective release system with high encapsulation efficiency and bio-stability. *Colloids and Surfaces. B, Biointerfaces*, 2013, 112: 492–498
- [10]. Parumasivam T, Leung S S Y, Quan D H, Triccas J A, Britton W J, Chan H K. Rifapentine-loaded PLGA microparticles for tuberculosis inhaled therapy: Preparation and in vitro aerosol characterization. *European Journal of Pharmaceutical Sciences*, 2016, 88: 1–11
- [11]. Nath S D, Son S, Sadiasa A, Min Y K, Lee B T. Preparation and characterization of PLGA microspheres by the electrospraying method for delivering simvastatin for bone regeneration. *International Journal of Pharmaceutics*, 2013, 443(1-2): 87–94
- [12] Anderson, J. M., & Shive, M. S. (1997). Biodegradation and biocompatibility of PLA and PLGA microspheres, 28, 5–24.
- [13] Sani, S. N., Das, N. G., & Das, S. K. (2009). Effect of microfluidization parameters on the physical properties of PEG-PLGA nanoparticles prepared using high pressure microfluidization, 26(6), 556–561. <https://doi.org/10.1080/02652040802500655>
- [14]. Cho, M., & Sah, H. (2005). Formulation and process parameters affecting protein encapsulation into PLGA microspheres during ethyl acetate-based microencapsulation process, 22(February), 1–12. <https://doi.org/10.1080/02652040400026269>